

Arrows show direction of rotation with airflow direction as shown (Reverse port connections A & B for opposite rotation)

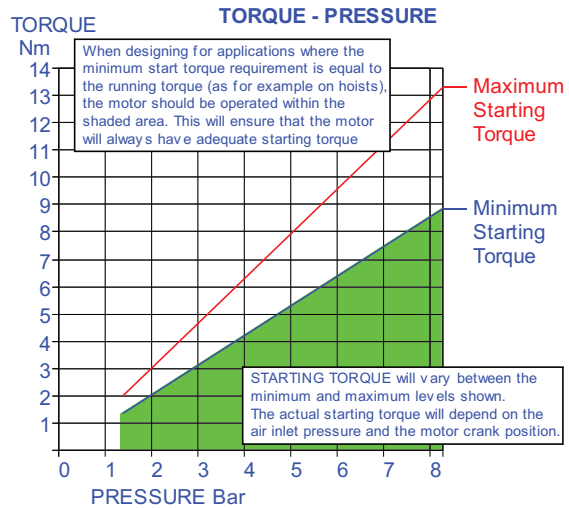

Gearbox ratio None Maximum continuous speed 2400 rpm

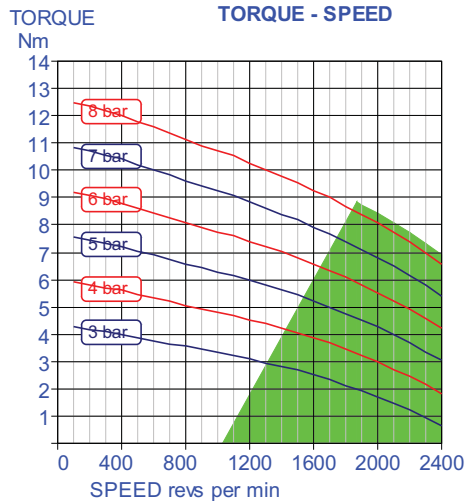

A pressure regulator should be used to control the air pressure to the motor, to limit the maximum output torque applied to the driven assembly.

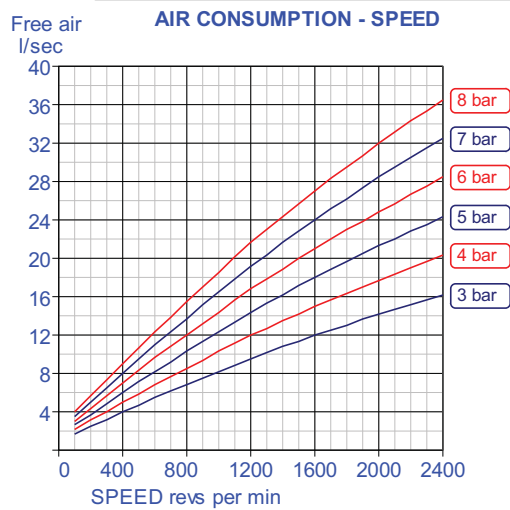
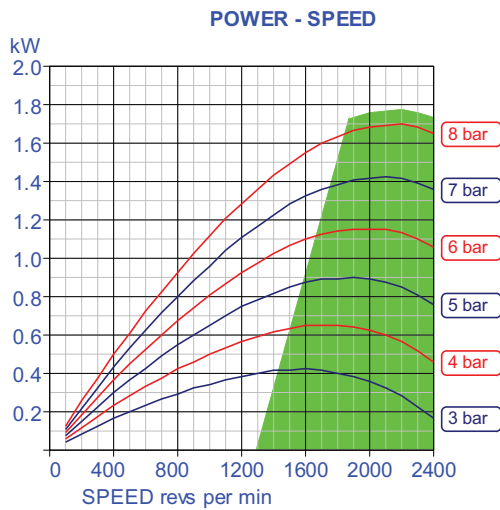

It is desirable that the motor's continuous operating speed is as close as possible to the speed at which PEAK POWER is achieved, since this gives optimum performance and air consumption.

LUBRICATING OIL CAPACITIES

Horizontal 75ml Vertical 150ml
Use a good quality hydraulic oil with a viscosity of around 100cSt (460SSU) at 40°C (104°F)

AIRLINE FILTRATION AND LUBRICATION

Use 64 micron filtration or better. Choose a lubricator suitable for the flow required. Prior to initial start-up, inject oil into the inlet port.
Lubricator drop rate 3-4 drops/minute continuous operation
Lubricator drop rate 6-8 drops/minute intermittent operation

GENERAL DATA

MASS (motor only) 13 kgs (28.7 lbs)
MOMENT OF INERTIA of rotating parts 0.01 gm² (motor only)
MAX OVERHUNG FORCE on motor shaft 445 N (100 lbf)
TEMPERATURE RANGE -20°C to +80°C (-4°F to +176°F)

RM110 Parking Brakes

The brake module bolts directly onto the motor mounting face and has exactly the same interface as the motor. As shown on the drawing below, the brake consists of two spring applied shoes pressed against a central hub. These shoes are released by applying air pressure to the cylinder / piston assembly. The brake torque can be varied by means of two spring adjusters but it is normally set so that a pilot pressure of 4.1 bar (60 p.s.i.) will fully release it. Pressures below this level will progressively reduce the braking torque available. The brakes are set at the plant but it the operating pressure of the brake **MUST** be set on installation to suit the individual application.

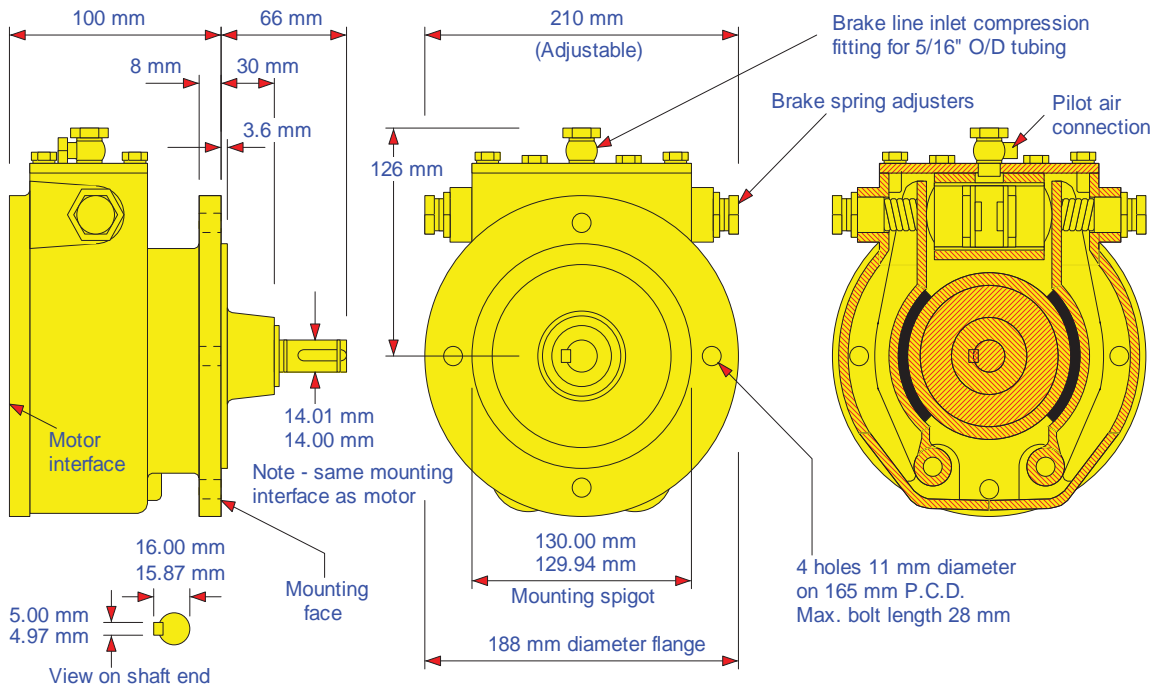

This is a Parking Brake ONLY. It MUST NOT be used in a Dynamic application

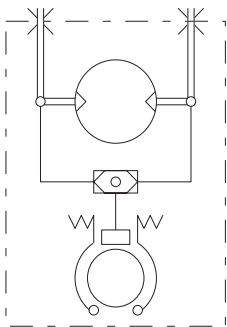

Circuit A

Circuit A Applies to braked motors supplied without control valving. The unit will be fitted with a shuttle valve to allow brake operation for dual rotation.

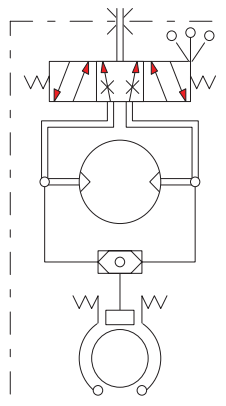

Circuit B

Circuit B Units supplied with hand (HCV) controlled reversible valves. If trips are required they must be of the mechanical style (customer's supply).

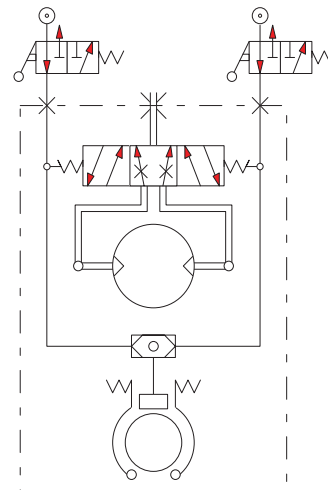

Circuit C

Circuit C Units supplied with remotely controlled valves. When override trips are required, they must be superimposed in the signal line close to the motor unit and be of the 3 way style (Signal lines cut and exhausted in the tripped position.)

RM110 Control Valve Options

REMOTE CONTROL VALVE

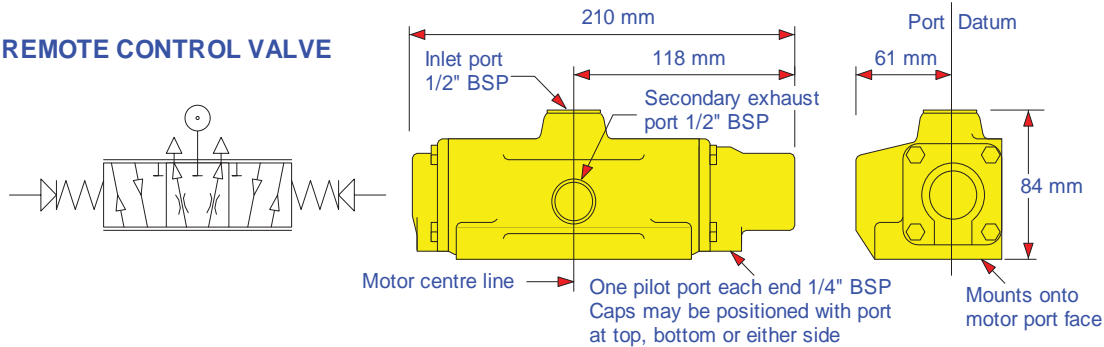

HAND CONTROL VALVE

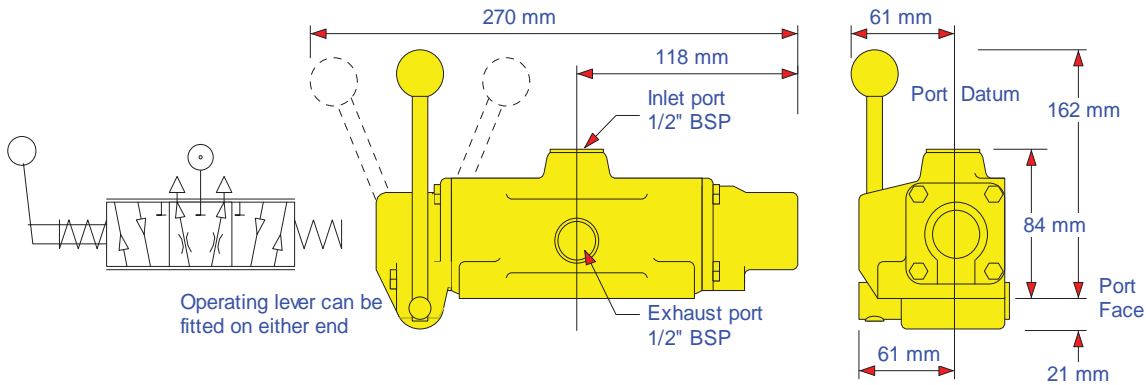

This range of bolt on valves offers very sensitive speed and directional control. One frictional matched spool and sleeve assembly is offered with two alternative means of actuation.

CONFIGURATION

As standard these valves can be supplied with either EQUAL POWER OR BIASED POWER spools, the latter is suitable for hoisting applications (normal power for lifting - reduced power for lowering).

The direction of reduced power must be stated when ordering CW or CCW, when viewed on the output shaft of the motor or geared motor.

1. REMOTELY CONTROLLED (RCV) - This option is usually controlled from a remote position by one of the PC series or LC2 remote controllers. A variable air pilot signal is applied to either end of the valve spool, depending on the required direction of motor rotation. The pilot pressure range is between 1.4 bar (20 psi) and 4.8 bar (70 psi), increased pilot pressure gives increased speed. The valve is spring centred to neutral.

2. HAND CONTROLLED (HCV) - The control valve spool is operated directly by a lever mechanism. Speed increase is obtained as the lever is moved in either direction from the centre (neutral) position.

PRESSURE DROP - Minimal pressure drop will be experienced through the valves, having the effect of maintaining the output torque whilst reducing the motor output speed by approximately 10-15% at 6 bar (90 psi) at maximum power. The starting torque remains unaffected.

Remote Controllers

PENDANT CONTROLS (PC2, 4 or 6)

The PC2, 4 and 6 remote controllers are designed specifically for use with the remote control valves (RCV range). They provide the correct range of pilot pressure required to operate the RCV units, and give excellent control of motor speed. The PC2 is used to control one (hoist) motor; the PC4 can control two motors independently (say hoist and long travel); the PC6 can control three motors independently (hoist, long travel, traverse). Motors of different sizes can be controlled from the same unit. Control line lengths of 36m (120ft) give excellent response. For distances in excess of this consult SPX Fluid Power or distributor. The control lines are small bore eliminating the need for large capacity air supply lines between motor and controller. If required, supply pressure can be taken from the tapping on the RCV. MARINE VERSIONS AVAILABLE. PC2M, PC4M or PC6M.

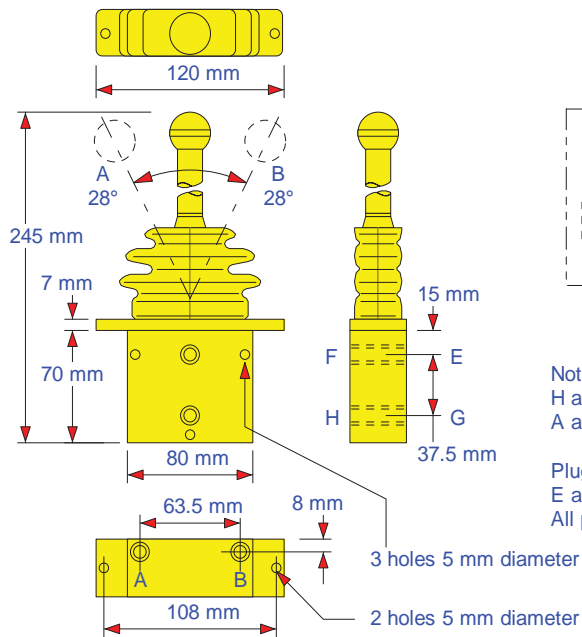
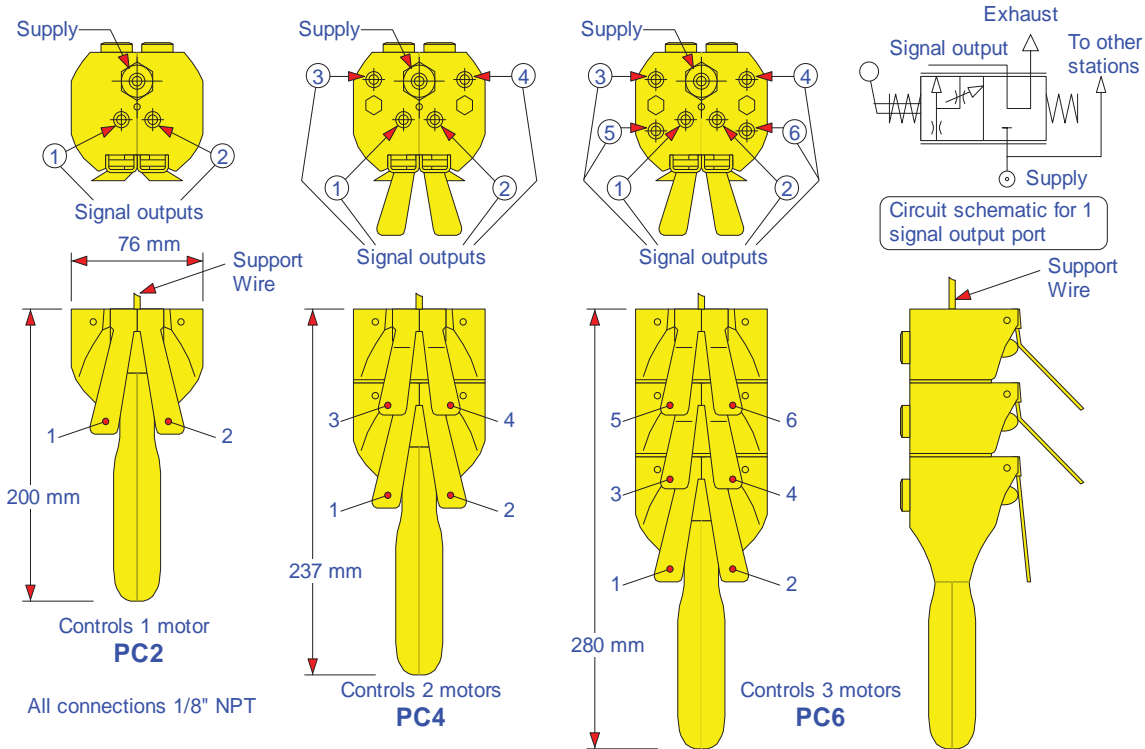

LEVER CONTROL (LC2) MARINE STYLE (LC2M)

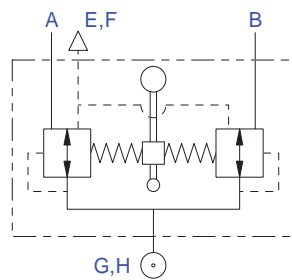

Circuit Symbol
Lever Control Valve

Note:
H and G are alternative supply ports.
A and B are outlet ports.

Plug alternative ports not connected.
E and F are exhaust ports.
All ports are 1/8" BSP

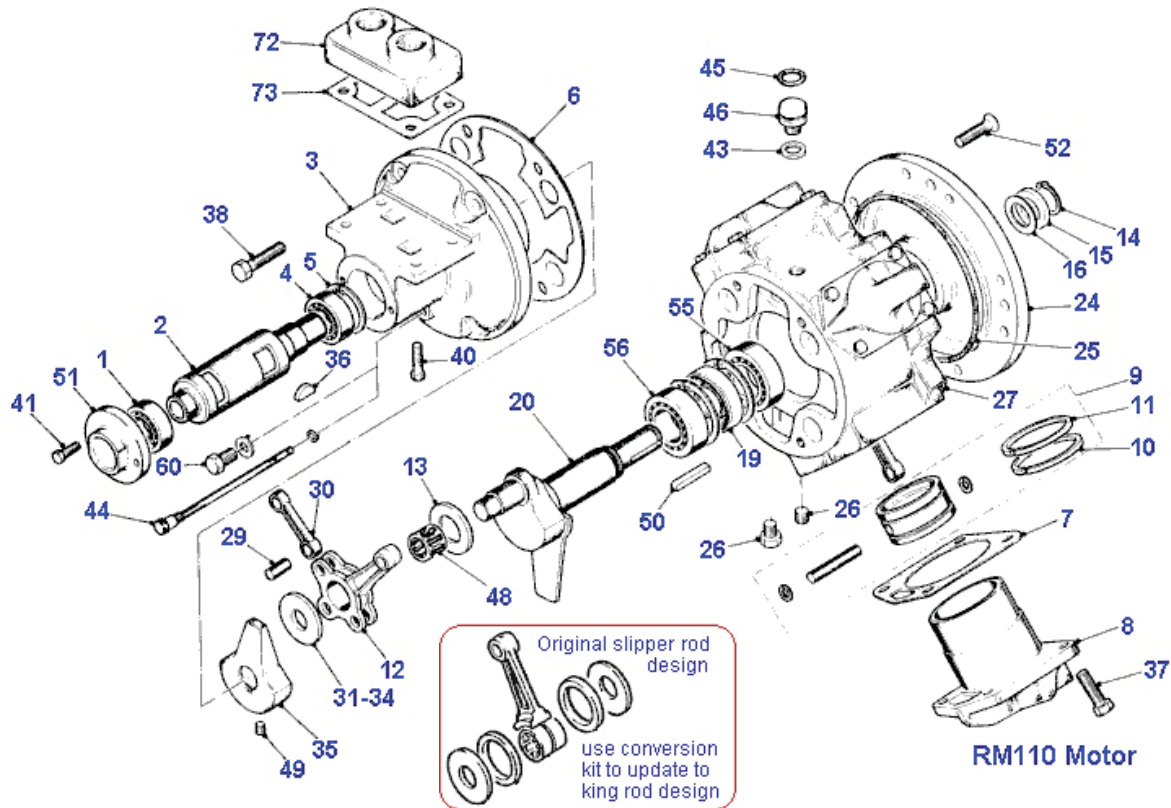

RM110 Motor

Item	Part No.	Description	Qty	Kit No.	Item	Part No.	Description	Qty	Kit No.
01	807-020	Rotary Valve Bearing (Outer)	1		37	802-020	Cylinder Bolts	16	
02	130-006	Rotary Valve	1		38	802-020	Valve Housing Bolts	4	
03	130-011	Rotary Valve Housing	1		40	802-020	Adaptor Plate Bolt	4	
04	807-021	Rotary Valve Bearing (Inner)	1		41	802-016	Exhaust Cover Bolts	2	
05	804-051	Rotary Valve Bearing Circlip	1		45	-	Seal (transit only)	1	
06	-	Rotary Valve Housing Gasket	1	139-911	46	130-066	Breather Plug	1	
07	-	Cylinder Gasket	4	139-911	48	807-042	Needle Bearing	1	
08	110-082	Cylinder	4		49	815-012	Grub Screw	1	
09	130-902	Piston Assembly	4		50	811-002	Key	1	
10	-	Compression Ring	4	139-911	51	130-005	Rotary Valve Exhaust cover	1	
11	-	Oil Control Ring	4	139-911	52	810-003	Countersunk Flange Bolt	8	
12	140-077	King rod	1		55	807-007	Output Shaft Brg (Outer)	1	
13	140-013	Crank Pin Spacer	2		56	807-007	Output Shaft Brg (Inner)	1	
14	804-006	Crankshaft Circlip	1		60	816-063	Oil Level Plug	1	
15	100-035	Crankshaft Spacer	1		72	130-003	Inlet Adaptor Plate	1	
16	100-049	Crankshaft Spacer Shim	5		73	-	Inlet Adaptor Plate Gasket	1	139-911
18	804-051	Crankshaft Bearing Circlip	2			149-920	Conversion Kit	-	
19	-	Oilseal	1	139-911		139-911	RM110 Seal kit	-	
20	110-901	Std Crankshaft Assembly	1						
24	130-076	Std Flange Plate	1						
25	-	Flange Plate Seal	1	139-911					
26	816-074	Plug	1						
27	130-012	Engine Case	1						
29	140-081	Queen Rod Pivot	3						
30	140-078	Queen Rod	3						
31	140-052	Crank Spacer * SELECT	1						
32	140-053	Crank Spacer * ON	1						
33	140-054	Crank Spacer * ASSEMBLY	1						
34	140-055	Crank Spacer *	1						
34a	140-056	Crank Spacer *	1						
35	130-010	Balance Weight	1						
36	811-016	Woodruff Key	1						

149-920 Conversion kit:
comprises of items 12, 13, 29, 30, 31-34 and 48.
These items may be used to convert a motor from
the original design to the king rod design.
If unit is pre 1990 supply consult manufacturer
to confirm design

Distributed in Australia by



PT Hydraulics Australia Pty Ltd
19 Ricketts Rd,
Mt Waverley,
VIC 3149

P: +61 3 9562 8800
F: +61 3 9562 8080

E: sales@pthydraulics.com.au



The information contained in this data sheet
may change without notification.

November 2005

Fluid Power Products

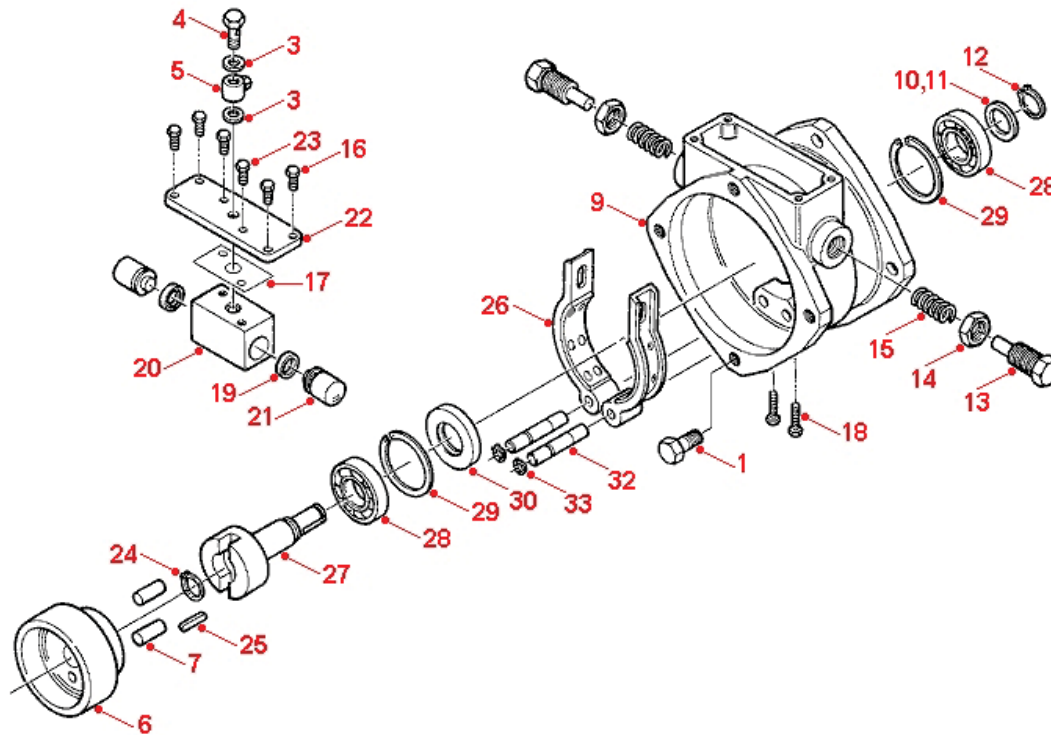

Item	Part No.	Description	Qty
1	802-052	Set Screw M10 x 20	4
3	808-090	Bonded Seal 1/4"BSP Dowty	2
4	816-004	Banjo Bolt Only 1/8 BSP	1
5	816-005	Banjo Body C/W Nut&Rin 5/16	1
6	112-001	Brake Wheel	1
7	806-001	Dowel Dia 10 x 30 Lg	2
9	112-008	Brake Housing	1
10	100-049	Shim - Output	5
11	100-035	RM100 Output Shaft Spacer	1
12	804-006	Circlip 19mm External	1
13	102-009	Brake Spring Adjuster	2
14	102-024	1/2" BSP Hex Nut	2
15	814-002	Spring 223612	2
16	802-016	Hex Head Screw M6 x 16	4
17	112-030	Piston Block Gasket	1
18	802-020	Hex Head Screw M6 x 20	2
19	808-072	U Packing U110	2
20	112-014	Piston Block	1
21	102-011	Brake Piston	2
22	112-013	Block Support Plate	1
23	802-012	Hex Head Screw M6 x 12	2
24	804-003	Circlip 14mm External	1
25	811-022	Key K123 5Sq	1
26	112-901	Brake Shoe Assembly	2
27	112-005	Output Shaft	1
28	807-007	Ball Bearing	2
29	804-051	Circlip 47mm Internal	2
30	808-043	Oilseal 20x47x10/R4	1
32	112-003	Brake Shoe Pivot	2
33	804-121	Circlip 3/8" External Ander	2

RM110 Hand Control Valve Spare Parts List

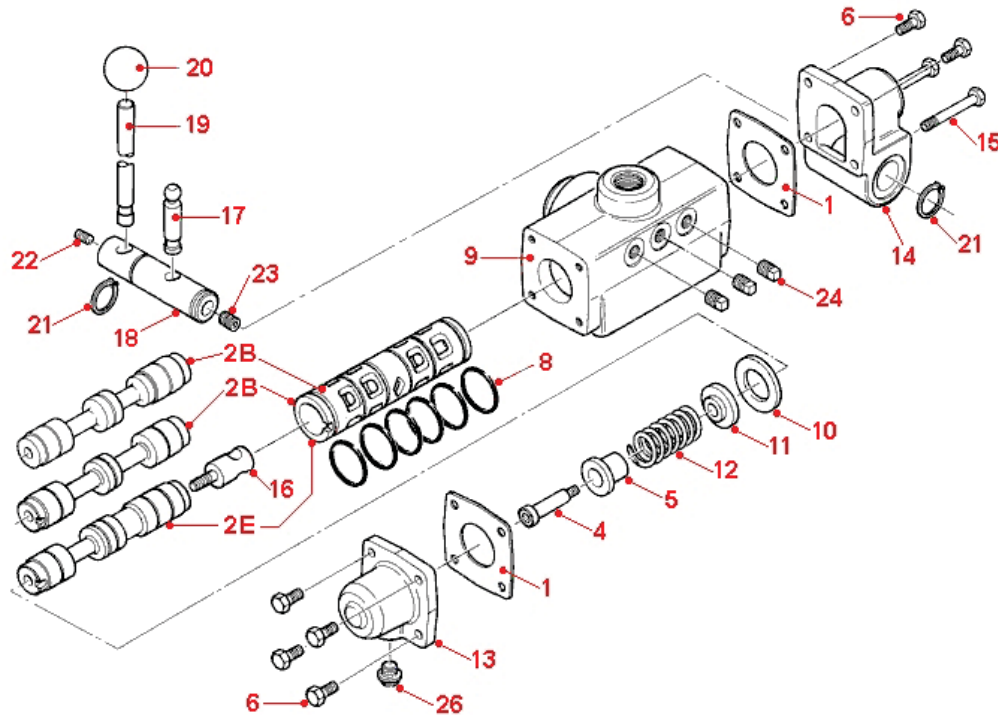

Item	Part No.	Description	Qty
1	111-066	End Cap Gasket	2
2E	111-913	Matched Spool and Sleeve	1 (Equipower)
2B	111-914	Matched Spool and Sleeve	1 (Biased)
4	817-003	Shoulder Screw 8 mm	1
5	111-071	Centering Shaft Guide	1
6	802-016	Hex Head Screw M6 x 16	6
7	111-065	End Cap - Plain End	1
8	808-027	O Ring 27, 5 x 30	6
9	111-060	Valve Body	1
10	111-068	Valve Sleeve Spacer	1
11	111-072	Washer, Spring Centering	1
12	814-016	Spring 323714	1
13	111-064	End Cap - Spring End	1
14	113-041	Lever Cap	1
15	802-024	Hex Head Bolt M6 x 50	2
16	113-024	Toggle Shaft	1
17	113-026	Toggle Pin	1
18	113-008	Hand Lever Pivot	1
19	113-002	Hand Lever	1
20	818-003	Black Plastic Knob 31 mm	1
21	804-013	Circlip 20mm External	2
22	815-010	Grub Screw M8 x 10	1
23	815-002	Grub Scev M8 x 16	1
24	816-063	Plug 1/8" BSPT Sq. Head	3
26	113-050	Vent Plug	1

Distributed in Australia by



PT Hydraulics Australia Pty Ltd

19 Ricketts Rd,
Mt Waverley,
VIC 3149

P: +61 3 9562 8800

F: +61 3 9562 8080

E: sales@pthydraulics.com.au



The information contained in this data sheet
may change without notification.

November 2005

Fluid Power Products

RM110 Remote Control Valve Spare Parts List

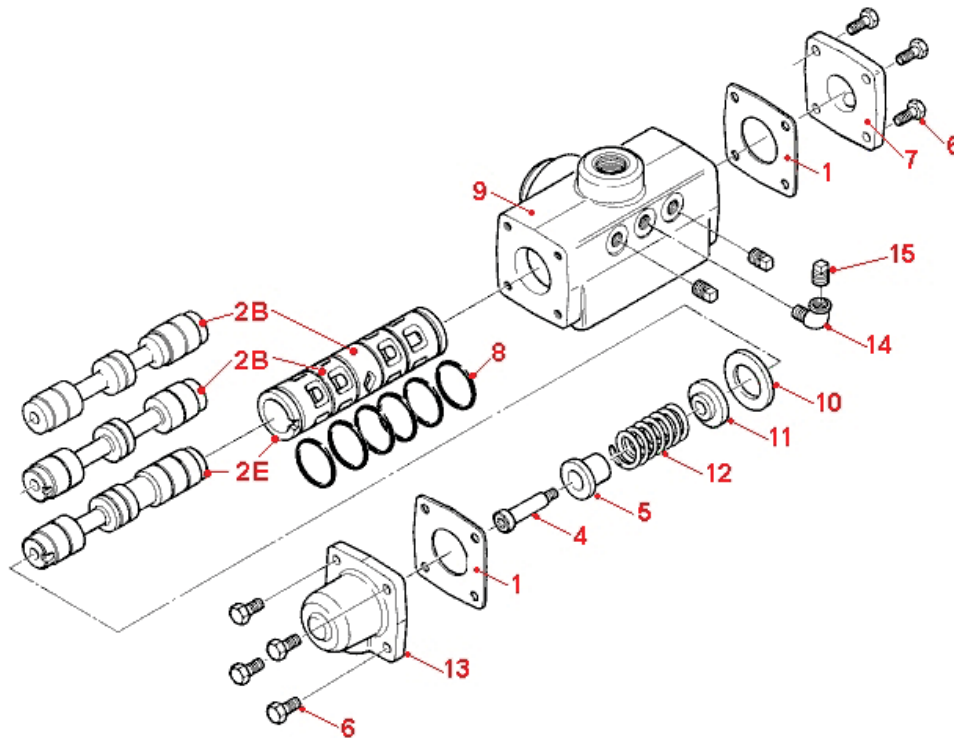

Item	Part No.	Description	Qty
1	111-066	End Cap Gasket	2
2E	111-913	Matched Spool and Sleeve	1 (Equipower)
2B	111-914	Matched Spool and Sleeve	1 (Biased)
4	817-003	Shoulder Screw 8 mm	1
5	111-071	Centering Shaft Guide	1
6	802-016	Hex Head Screw M6 x 16	8
7	111-065	End Cap - Plain End	1
8	808-027	O Ring 27, 5 x 30	6
9	111-060	Valve Body	1
10	111-068	Valve Sleeve Spacer	1
11	111-072	Washer, Spring Centering	1
12	814-017	Spring D13040	1
13	111-064	End Cap - Spring End	1
14	816-049	Elbow M/F 1/8" BSPT	1
15	816-063	Plug 1/8" BSPT Sq. Head	3

Distributed in Australia by



PT Hydraulics Australia Pty Ltd
19 Ricketts Rd,
Mt Waverley,
VIC 3149
P: +61 3 9562 8800
F: +61 3 9562 8080
E: sales@pthydraulics.com.au



The information contained in this data sheet may change without notification.

November 2005

Fluid Power Products

RM110 Air Motor Foot Bracket

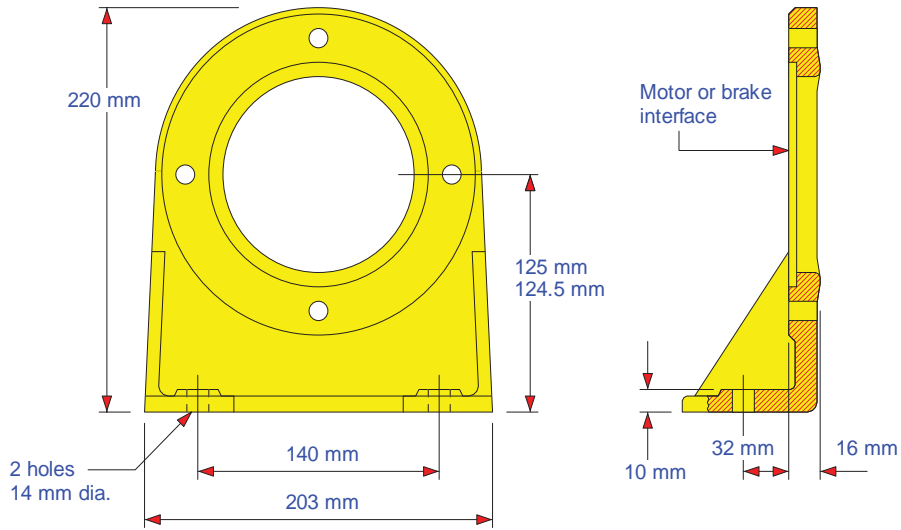

INSTALLATION

1. Mounting Positions

The motor is normally mounted in a horizontal position with the filler / breather plug towards the top (Fig. 1) It may also be mounted with the shaft vertically downwards (Fig. 2). As supplied the motors have been run up and tested using protective oil and then drained for transit.

It is vital that each motor is re-filled to the correct oil level as shown below.

The RM110 - 310 motors have a dipstick for vertical mounting (Fig. 2) and the lower mark on this dipstick provides the oil level. Oil levels are achieved on motors in the horizontal position by filling to the plugs marked 60 (RM110 - 410 models) and plug 26 (fitted in housing 3 RM510 - 610 models).

(numbers indicate parts on exploded view)

The vertical oil level position for the RM410, RM510 and RM610 motors is a combined horizontal drain and vertical level plug (part number 26)

To fill motors with oil remove the combined breather and oil filler plug part number 46. Ensure breather plug is in the vertical position. It may be necessary to fit an elbow between the breather plug and the motor (see Fig. 2).

2. Recommended Lubricants for normal ambient temperature (0 - 32 deg. C.)

	Crankcase	Airline
Shell	TELLUS 100	TELLUS 37
B.P.	ENERGOL HL175	ENERGOL HLP65
Esso	NUTO H.64	FANOX 38
Regent	REGAL PE.RO	RANDO 'A'
Castrol	HYSPIIN 175	HYSPIIN 70
Mobil	D.T.E. EXTRA HEAVY	ALMO OIL NO. 1

For extremes of ambient temperatures consult the manufactures

3. Air Inlet

The motor is normally supplied with inlet / exhaust adaptor plate (72). All motors are reversible.

4. Air Supply. Maximum Working Pressure 8 bar - 120 psi

The air supply must be clean and free from moisture. An airline filter and mist lubricator should be incorporated in the air supply line, located immediately before the motor. If the rated performance of the motor is to be obtained all valves and pipework must be of adequate size. Valves should be sited as close as possible to the motor.

For short pipe runs e.g. up to 2 metres the supply line should be the same size as the motor ports and larger for longer runs.

5. Fitting

Mount motor in operating position. Check oil level. (as 1 above). Before connecting to the air supply blow out the air lines to remove any loose scale, swarf or abrasive dust which may be present.

Remove the red plastic dust-caps and the 'O' ring seal (45).

For unidirectional operation check the required direction of rotation and connect the air supply line to the appropriate port on the inlet / exhaust adaptor plate (72) leaving the other port open or pipe downwards if exposed to the atmosphere.

The motor should not be allowed to race. Always operate within the catalogue speed curves.

Motor Mounting Positions

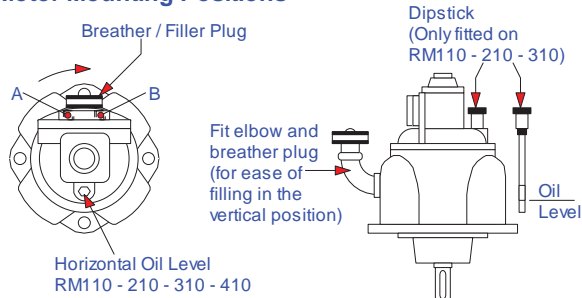

Fig. 1

Fig. 2

Shaft rotation as shown with inlet 'A'
Reverse rotation is obtained with inlet at 'B'

Note! When first running the motor some light oil should be injected into the inlet connection to ensure adequate lubrication until the airline lubrication is established.

Maintenance

6. Air Supply

The air filter should be drained regularly and examined for clogging of the element.

The air line lubricator should be replenished as required

and set to give	3-4 drops per minute RM110
	4-5 drops per minute RM210
	5-6 drops per minute RM310
	6-8 drops per minute RM410
	6-8 drops per minute RM510
	8-10 drops per minute RM610

Double the above drip rate if intermittent operation.

7. Motor

The oil level in the motor casing must be maintained. The frequency of replenishment will depend on the application and usage.

The motor case should be drained and refilled after 25 hours of initial running and every 200 hours thereafter or sooner if found necessary e.g. (contamination of oil by water from the air line.)

Fault Finding

1. The RM series motors are designed to perform at their rated capacities for the long periods of time. Faults can develop for the following reasons:

(A) Lack of lubrication. This will leave to rapid wear, internal seizure, loss of power or excessive air leakage.

(B) Faults in the air supply system:

- failure to remove the plastic protective dust caps
- insufficient air pressure at the motor caused by (a) supply pipe line or valve too small (b) if the exhaust is piped away excessive back pressure due to small bore pipes (c) compressor of insufficient capacity (d) clogged airline filter (e) the air pressure should remain at the required pressure when the motor is operating at full potential.

If the air pressure reduces considerably from the stationary to the rotating conditions then the supply line or the compressed air available is inadequate for the service operation of the motor.

The motor should always be supplied with clean moisture free and lubricated air. The better the quality of the air the less attention will be required to the motor unit.

The information contained in this data sheet may vary without notification

November 2005

8. SERVICING

A. Preparation for stripping

Remove the motor from its operating position to a clean working surface ready for stripping, externally clean the motor ready for opening.

Drain the oil from the motor casing by removing the drain plug (26).

Stripping and re-assembly will be simplified if the crankshaft (20/A/B) or output shaft (67) RM510 and RM610 is held vertically in a soft-jawed vice or supported on a suitable packing to raise the shaft clear of the working surface.

B. Removal of Rotary Valve Housing assembly

Remove inlet / exhaust adaptor plate (72) or control valve (if fitted).

Remove valve cover (51)

Release bolts (38) and valve bush housing (3) can be eased upward.

On RM110 to 410 motors remove grub screw (49) together with the valve side balance weight (number 35).

All motors - carefully remove rotary valve (2) from the housing (3). This can generally be done from the inside outwards and inspect both the rotary valve and the housing for wear. The normal clearance at manufacture between these two components is 0.002 - 0.003" (0.05 - 0.075 mm). Excessive wear will cause air leakages and loss of efficiency of the unit.

RM 110 Motors only

Lift the spacing washers (31/34) out. Slightly rotate the shaft backwards and forwards and inspect the amount of wear which is present on the big end assembly. Remove the top retaining ring (part no. 74). All the connecting rods can then be lifted upwards and pushed outwards towards the cylinders. Remove cylinder bolts (37) and the entire piston assembly can be withdrawn from the motor unit.

Motors RM 210 / 310 / 410

These units are of the king rod variety and again it is wise to slightly rotate the crankshaft (part no. 20 A/B) in either direction to test any excessive wear on either the king rod bearing or the pivot pins (part no. 29). Having first removed the outer spacing washer (31/34) withdraw pivot pins (part no. 29). This procedure is usually done with a bent rod withdrawing the pins from the inside outwards. Remove all cylinder cap bolts (part 37) and by pushing the queen rods (part 30) outwards the entire piston and rod assembly can be removed from the motor.

Turn the motor unit over to extract the crank bearing or bearings (part no. 48). The main king rod (part no. 12) can then be lifted upwards and tilted over the top of the crankshaft. Remove the main king rod, piston and cylinder from the motor. Remove the output shaft circlip (14), spacer (15) and shims (16). Remove the counter sunk bolts (52) holding the output flange (24 / A, B) on to the engine case (part no. 27). The engine case (27) can be removed. Drift the crankshaft inwards from the flange plate (24A). To remove the outer shaft bearings (55 and 56) drift to their respective sides as they are located inwardly on the two circlips (part no. 18).

RM 510 and 610 Motors

Remove bolts (58) holding the output shaft assembly. Remove bolts (57) and the output flange (24 A/B). This will then expose the inside of the motor. Turn the crankshaft so that one rod is at T.D.C. Remove that cylinder, the retaining circlip and gudgeon pin. Push out from the piston and the entire assembly can be removed.

RM 510 and 610 Motors (continued)

Repeat this procedure in turn until all the pistons have been removed. On this motor the balance weight and crank assembly is built as one item and this can now be removed. Remove locking nut (22) and the tapered pin (21). Both balance weights (part no. 20A and 20B) can now be disengaged.

This will expose the king rod and queen rod assembly. To remove the queen rod remove the pivot pin (29).

All Motors

Inspect the clearance of the pivot pins (29) in queen rod (30) and king rod (12). Inspect the gudgeon pin in both the piston and all rods. Check for wear on the main crankshaft (20A, 20B) and on the main big end bearing (no. 48). The wear in the cylinder bores can be checked by removing each compression ring (10) and pushing it into the cylinder bore (8). The ring gap should be in the region of 0.003 to 0.004" (0.075 - 0.010 mm). Bore wear cause loss of power and inject high pressure air into the case & oil could be ejected from the breather plug (part no. 46). All other parts should be thoroughly cleaned and inspected for wear.

Spare parts can be found from the spare listings.

The motor number and its code should be incorporated in any spares order. This is always stamped on the main flange plate (24) located near the breather plug hole 46, i.e. 230 Hx.

SPX provide a seal kit for each motor and it is strongly recommended that new oil seals, seals and gaskets are used throughout.

9. ASSEMBLY PROCEDURE

All parts should be clean and liberally coated with oil.

RM 510 and RM 610 motor only

Assemble the spacing washer (13) on to the crankshaft outer section locating the dowell pin (23). Assemble bearing (48) and the king rod (12). Assemble all four queen rods (part no. 30) into the king rod (12) locating with pivot pins (no. 29).

Fit final location washer (13) to close the assembly.

Ensure that the drive peg (23) is fitted on to the inner balance weight (20 A / B). Closed together and finally rotated to locate correctly by passing a 12 mm dia. bar between the holes marked X and Y on the drawings. Once this assembly is located the locking dowell (21) and its nut can be assembled, remove the 12 mm bar and ensure that the mechanism is free. Locate assembly into open engine case. Ensure each rod projects into its correct cylinder. Rotate the unit so that the main king rod comes to top dead centre, fit the piston and gudgeon pin, ensure gudgeon pin circlip is correctly located. Fit gasket (7) to cylinder (8).

Fit pistons into cylinder bore using a piston ring clamp.

Bolt cylinder (8) on to engine case (27). Rotate the crank to the next top dead centre position and repeat the procedure. Turn crank 360 degrees to check correct functioning. Fit gasket (28) and the output flange (24 A / B). Turn the motor 180 degrees to allow valve to be fitted.

Lubricate valve (2) and Inside Bore of Housing (3).

Rebuild the valve assembly in the reverse order. Check it rotates freely. Fit valve assembly on to the motor ensuring the different size drive dowells (61) and (62) are located in the crankshaft. The remaining build procedure is the reverse to initially dismantling.

RM 110 to RM 410 motors continued on next page...

ASSEMBLY PROCEDURE (continued)

All parts should be clean and liberally coated with oil.

RM 110 to RM 410 motors

Output shaft assembly. Ensure both circlips and bearings are fully home. Oilseal (19) lip must face inwards and be lubricated. RM410 motor has also a spacer fitted between bearings. Push crankshaft fully home and locate spacer washer (15) and circlip (14). Check gap, shim up (16) for minimum end float. Fit new seal (25) and output flange (24) to the engine case (27). Turn motor vertical (shaft downwards).

RM 110 motor only

Fit crank spacer (13) bearing (48) and the inner retaining ring (74) (internal bevel uppermost). Assemble con rods on pistons. Assemble all pistons into their cylinder pots (8) using ring clamp.

Fit all pistons / cylinder on to engine case. Carefully lift the connecting rods (53). Lift upwards and locate the shoe on the connecting rod between the bearing (48) and the retaining ring (74). Repeat for all cylinders. Locate the outer retaining ring (74) (internal bevel downwards) over all shoe on the connecting rods (53). Fit the packing spacer (31 / 34). Refer to motor spacing assembly. Paragraph No. 10.

Assembly of RM 410 motor big end

Fit all connecting rods (30) & (12) on to gudgeon pins and pistons using ring clamp assemble into cylinders. Ensure gudgeon pin circlips are seated correctly. Rotate motor until crank is nearest to breather plug (46). Fit the crank spacer (13) push the piston to bottom dead centre within the cylinder (8). Insert the king rod into the engine case (27) lifting and rotating the king rod (12) over the top of the crankshaft (20 A / B). Bolt cylinder in position, fit the 2 crank bearings (48). Fit remaining cylinders / pistons and attach to king rod (12) with the pivot pin (29). Rotate 360 degrees to ensure parts are correctly fitted. Locate the spacing washer (31 - 34) and spacing as paragraph No. 10.

Crank assembly instructions for RM 210 and RM 310 motors

fit the 3 queen rods (30) on to piston assembly (9) and assemble into the cylinder pot (98) complete with gasket (7). Fit piston assembly (9) on to the king rod (10) ensuring gudgeon pin clips are correctly positioned. (RM310 motor). Assemble a ring clamp (dimensions shown on sketch) on to the king rod piston.

Fit the crank spacer (13) to the crankshaft (20 A / B). Rotate the crankshaft until the crank pin is in the vertical position (nearest the breather plug 46). Feed king rod (12) complete with its piston assembly through the aperture marked 'Z' on drawing.

Twist and lift the rod over the end of the crank pin. Fit crank pin bearing or bearings. Feed the cylinder pot (8) complete with its gasket (7) on to the piston. The ring clamp is ejected inwards from the piston. Work clamp off sideways from the king rod.

Bolt the cylinder pot into position and feed the remaining cylinders completely assembled through the various holes and locate the inner end of the connecting rods with the king rod fixing with pin (29).

Rotate the motor 360 degrees to ensure correct fitting. Fit spacing washer (30/34) and refer to paragraph 10 for spacing the motor unit.

Assembly of valve housing

This is the reverse procedure to dismantling. Smear oil to external surface of valve (2) and to the bore of valve housing (3).

Spacing RM 110 - RM 410 motors

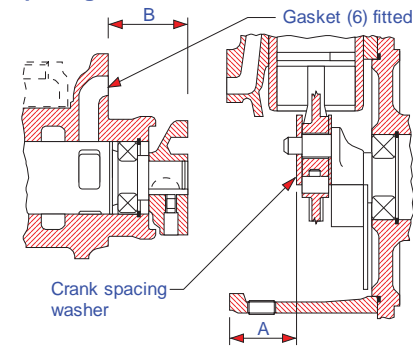

Fit spacing washer such that $A - B = 0.25$ to 0.50 mm (0.01" to 0.02") clearance

Crank spacing Washers

RM 110	RM 210	RM 310	RM 410
1.85 (0.073")	2.64 (0.104")	3.24 (0.128")	2.50 (0.099")
2.03 (0.080")	3.25 (0.128")	3.66 (0.144")	3.00 (0.120")
2.34 (0.092")	3.66 (0.144")	4.06 (0.160")	4.00 (0.157")
2.64 (0.104")			

Dimensions in mm (and inches)

Measure dimension (A) from the crank washer face to the engine case and also dimension (B) from the rotary valve face to the inside of the gasket. Select the correct shim washer from the list (31 - 34) to obtain clearance.

Rotate the crankshaft until the balance weight is at the bottom dead centre position, rotate the rotary valve until the balance weight is at the bottom position. Assemble the valve housing (3) on to the engine case (27). Rotate the output shaft in both directions and viewing the rotary valve (2) through the exhaust cover (51) ensure that the valve is correctly following the output shaft direction, this checks that both crank and valve slot are correctly engaged.

Replace all drain plugs and refill with oil. Spray some light oil into the inlet and exhaust ports and connect the unit to a lowpressure supply and allow the unit to run on the bench for a short period of time prior to refitting the unit into full service.

Piston Ring Clamp Details

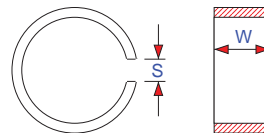

	W	S
RM 210	32mm (1.25")	25mm (1.00")
RM 310	45mm (1.75")	16mm (0.625")

NOTE: these items can be cut from an old cylinder

RM Air Motor Installation / Maintenance / Servicing

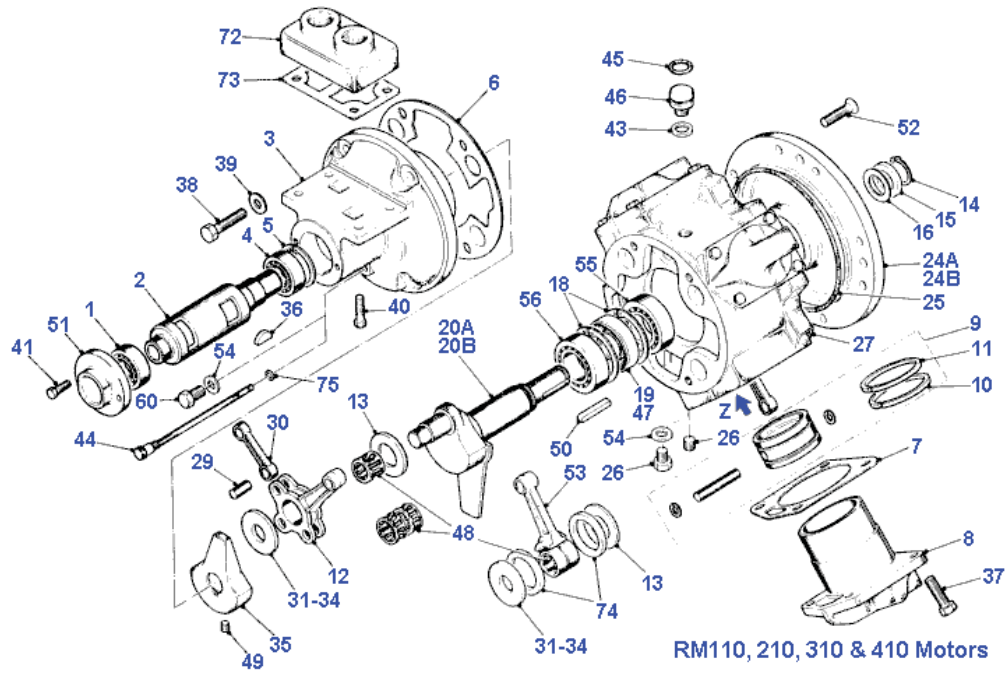

RM Air Motor Installation / Maintenance / Servicing

