

An industrial facility, possibly a refinery or chemical plant, is silhouetted against a vibrant sunset sky. The sky transitions from a deep orange at the horizon to a darker red at the top. Numerous lights are visible on the facility, some appearing as bright starbursts. A large, semi-transparent circular graphic is overlaid on the scene, framing the central text.

GLOBE[®]

RADIAL PISTON AIR MOTORS



SPX[®]

HYDRAULIC TECHNOLOGIES

The Globe RM air motors are a series of compact heavy duty radial piston air motors offering an exceptional range of control valve and output options. The motors are four or five cylinder radial piston design with oil bath lubrication and are designed to develop greater power than other motors of equivalent size.

ADVANTAGES

- Modular motor, brake, gearbox and control valve options.
- Relatively inexpensive variable speed control
- Intrinsically safe in hazardous environments (e.g. mine, petro-chemical, etc.)
- Instantly reversible
- Resistant to dirty, damp conditions
- Positive start
- Rugged Design
- NEMA and S.A.E. interfaces
 - RM210, RM310, RM410, RM510 and RM610 motors can be supplied in configurations approximating to NEMA Interfaces.
 - RM410, RM510 and RM610 motors are also available with S.A.E. drives.
- ATEX & Non-ATEX gearboxes available.
- RM motors are most suitable for heavy duty applications and can be supplied direct coupled to gearboxes.
- Natural sweet gas & other gases can also be used. Contact SPX Hydraulic Technologies for details.
- For complete range of gearboxes, contact SPX Hydraulic Technologies for options.
- Variety of mountings

CONTENTS

Typical Selection Graphs	3
Ordering Codes	4-7
RM110 (4.7kW, 2.4HP)	
Peak Power 4.7kW (2.4HP) Performance Data	8
Motor Spare Parts List.....	9
Geared Motor Installation Details.....	10
Valve Options.....	11
Valve Options Spare Parts Lists	12
Parking Brake Installation Details	13
Parking Brake Spare Parts List & Foot Bracket	14
RM210 (4kW, 5.5HP)	
Peak Power 4kW (5.5HP) Performance Data	15
Motor Spare Parts List	16
Geared Motor Installation Details.....	17
Valve Options.....	18
Valve Options Spare Parts Lists	19
Parking Brake Installation Details	20
Parking Brake Spare Parts List & Foot Bracket	21
RM310 (7.5kW, 10HP)	
Peak Power 7.5kW (10HP) Performance Data	22
Motor Spare Parts List	23
Geared Motor Installation Details.....	24
Valve Options.....	25
Valve Options Spare Parts Lists	26
Parking Brake Installation Details	27
Parking Brake Spare Parts List & Foot Bracket	28
RM410 (14kW, 19HP)	
Peak Power 14kW (19HP) Performance Data.....	29
Motor Spare Parts List	30
Geared Motor Installation Details.....	31
Valve Options.....	32
Valve Options Spare Parts Lists	33
Parking Brake Installation Details	34
Parking Brake Spare Parts List & Foot Bracket	35
RM510 (22kW, 31HP)	
Peak Power 22kW (31HP) Performance Data.....	36
Motor Spare Parts List	37
Geared Motor Installation Details.....	38
Valve Options.....	39
Valve Options Spare Parts Lists	40
Parking Brake Installation Details	41
Parking Brake Spare Parts List & Foot Bracket	42
RM610 (23kW, 32HP)	
Peak Power 23kW (32HP) Performance Data.....	43
Motor Spare Parts List	44
Geared Motor Installation Details.....	45
Valve Options.....	46
Valve Options Spare Parts Lists	47
Parking Brake Installation Details	48
Parking Brake Spare Parts List & Foot Bracket	49
Remote Controllers	50
Accessories - Mufflers	51

TYPICAL SELECTION BASED ON RM110

GRAPH 1 TORQUE - SPEED

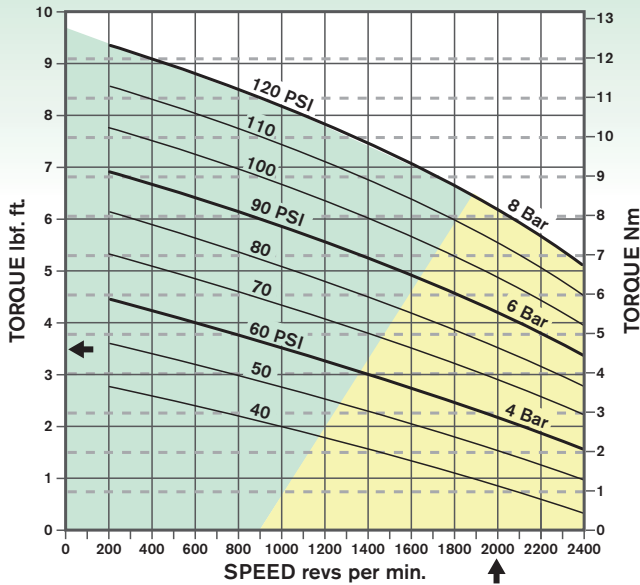

GRAPH 2 STARTING TORQUE - PRESSURE

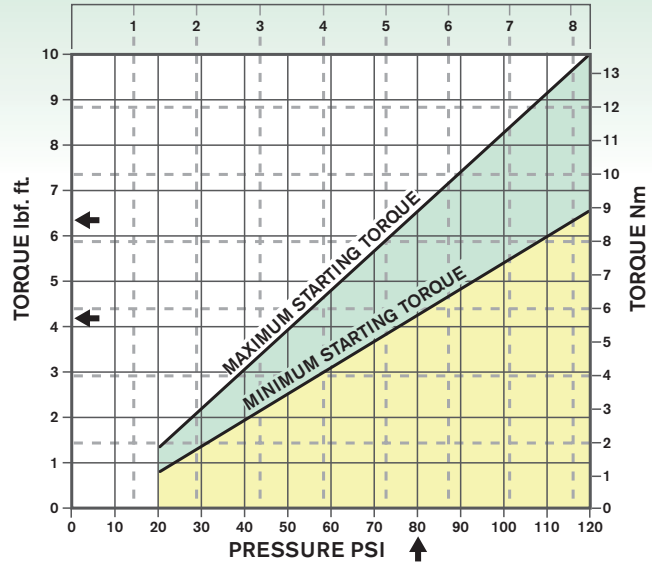

GRAPH 3 POWER - SPEED

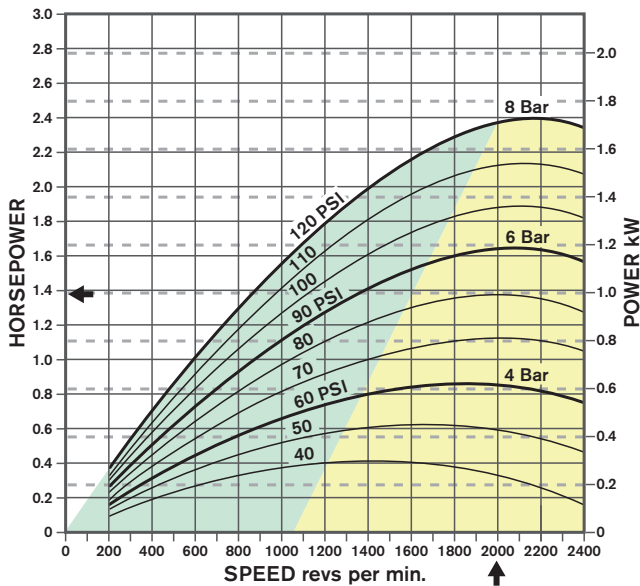

GRAPH 4 CONSUMPTION - SPEED

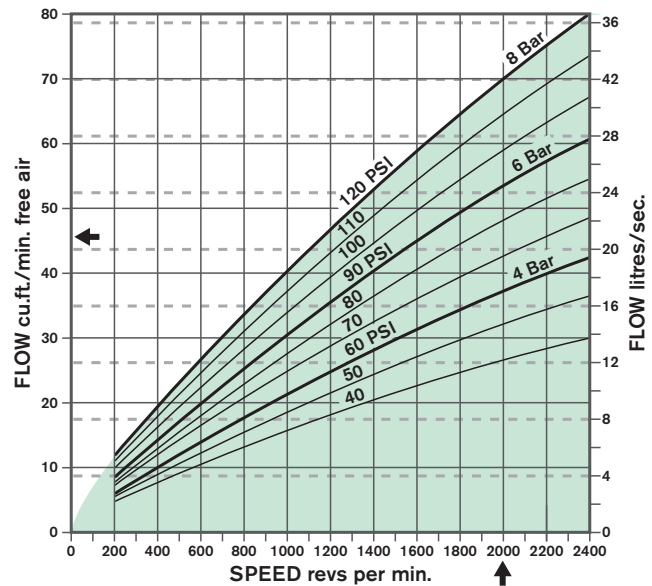

Reading Graphs - Scales have been adjusted to enable bar and psi to be read from a common curve. Therefore only read psi with the left hand axis and bar with the right hand axis.

MOTOR SELECTION

Motor performance can be derived from the above graphs as in the examples shown.

Where motors are not required to start under load, such as fan drives, selection may be made using either Graph 1 or Graph 3 using the required running torque or power only. For applications where the motor starts under load, such as hoists, winches or track drives, the starting torque in Graph 2 must also be considered. Starting torque varies between the maximum and minimum values shown, depending on the angular position of the output shaft.

- 1. Running torque example:** RM110 at 5.5 bar / 80 psi gives 4.74 Nm / 3.5 lbf. ft. torque at 2000 r.p.m.
- 2. Starting torque example:** RM110 at 5.5 bar / 80 psi gives between 5.694 Nm / 4.2 lbf. ft. and 8.813 Nm / 6.5 lbf. ft. at start depending on output shaft position.
- 3. Output power example:** RM110 at 5.5 bar / 80 psi gives 1.4 h.p. at 2000 r.p.m.
- 4. Air consumption example:** RM110 at 5.5 bar / 80 psi and 2000 r.p.m. requires 22.65 L/S / 48 cu.ft./min. free air.

ORDERING CODES

R43

DESIGN CODE
RM410 Air Motor

DESIGN CODE

- RM110 = (1.7kW, 2.4HP)-R14
- RM210 = (4kW, 5.5HP)-R23
- RM310 = (7.5kW, 10HP)-R33
- RM410 = (14kW, 19HP)-R43
- RM510 = (14kW, 31HP)-R52
- RM610 = (14kW, 32HP)-R62

K

18

NOMINAL GEAR RATIO
(XX = NO GEARBOX)

H

VALVE OPTIONS

- A = Motor with Inlet Plate
- H = Hand Lever Control Valve
- R = Remote Controlled Valve
- X = No Valving or Adaptor Plate

OUTPUT OPTIONS

- | | |
|---|--|
| <ul style="list-style-type: none"> X = Motor Only Maleshaft B = Motor + Base Mounted Gearbox (BG) C = NEMA 'D' Mounting Flange D = Motor + Brake F = Motor + Flange Mounted Gearbox (FG) G = "Sweet" Natural Gas Operation J = Foot Mounting Bracket | <ul style="list-style-type: none"> K = Motor + Brake + Flanged Gearbox L = Motor + Brake + Base Mounting Gearbox M = Motor Only Female Shaft N = SAE 'C' Hydraulic Pump Output V = Grease Lubricated for Shaft Upwards Operation X = Motor with Male Output Z = Motor with other Ancillaires not listed above |
|---|--|

EXAMPLE: R43K18H19N

RM410 motor with brake, flange mounted 18:1 gearbox and hand controlled valve with NPT ports, non-ATEX gearbox

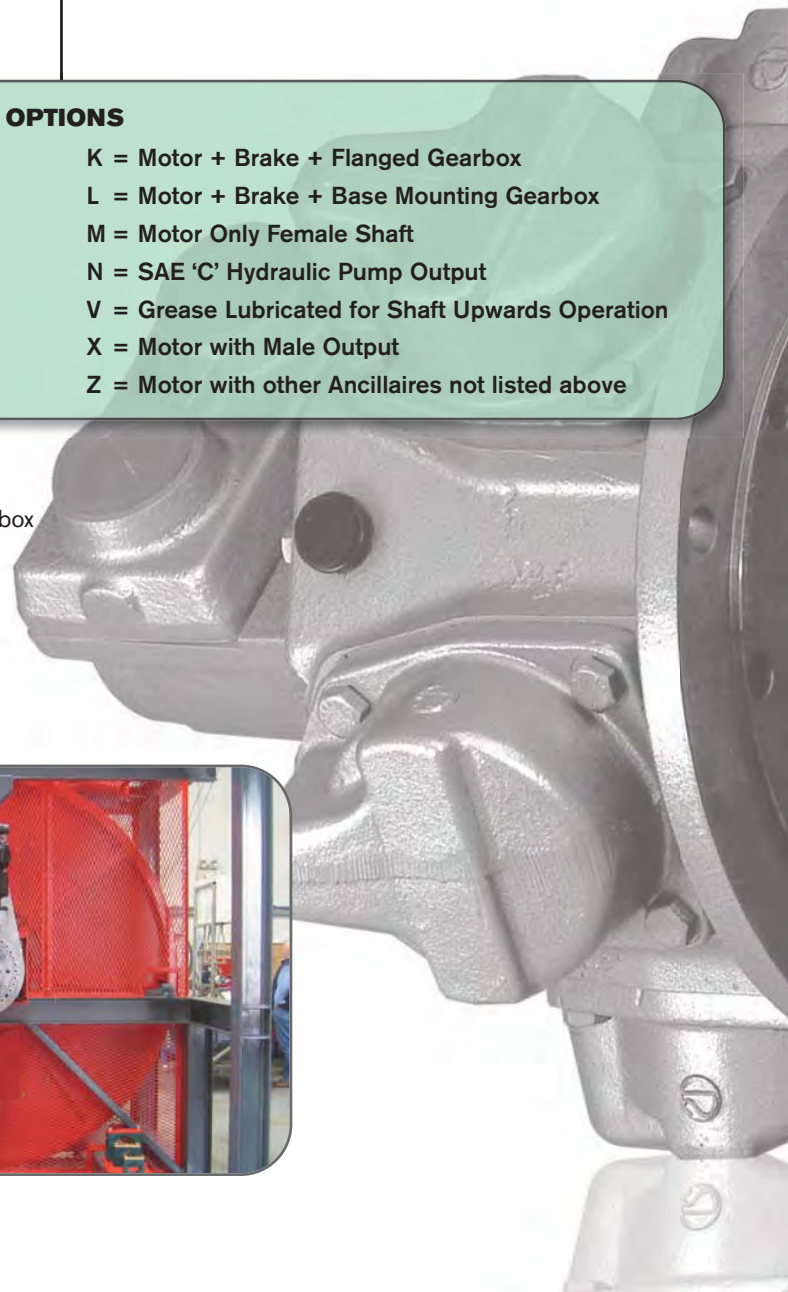

1

9

4

N

- 0 = Standard Motor & Ancillaries, for Standard Mounting
- 1 = Available for Non Standard Builds
- 2 = Available for Non Standard Builds
- 4 = Available for Non Standard Builds
- 5 = Heligear Gearbox
- 6 = Available for Non Standard Builds
- 7 = Tempo Gearbox
- 8 = Flender Modified Gearbox
- 9 = Flender Standard Gearbox

N = Non-Atex Gear Box

- 0 = Additional Gearbox Types
- 3 = Helical Bevel Gearbox 90 degree
- 4 = Parallel Shaft Gearbox

- VALVE**
- 0 = BSP } Equal Power
 - 1 = NPT } Both Rotations
 - 2 = Biased: CW Lowering (BSP)
 - 3 = Biased: CCW Lowering (BSP)
 - 4 = Biased: CW Lowering (NPT)
 - 5 = Biased: CCW Lowering (NPT)

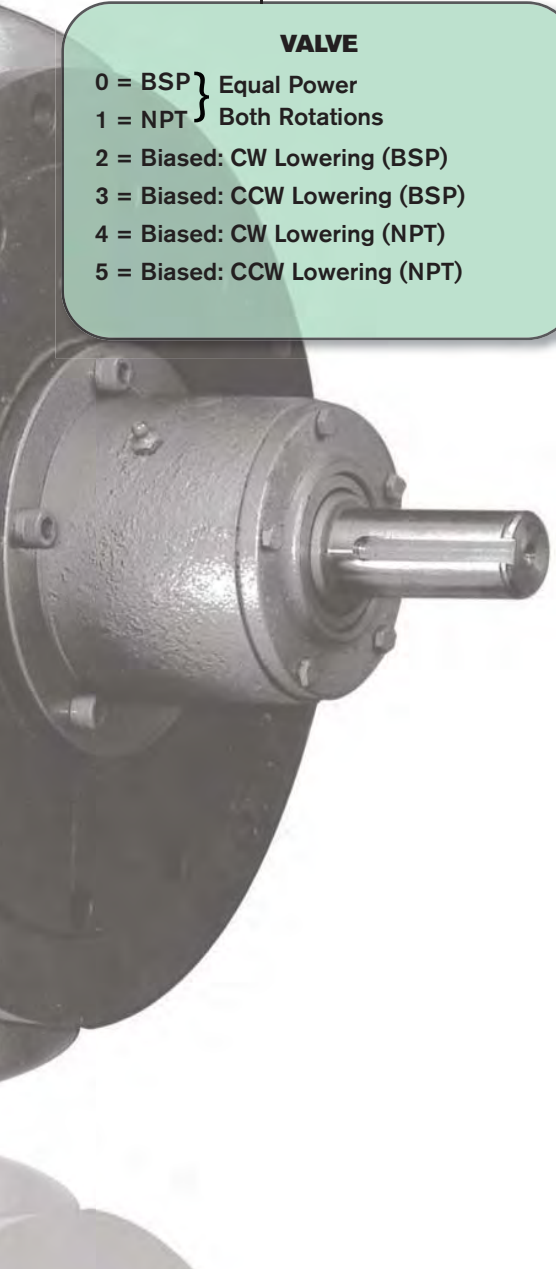

CONFIGURATIONS

ORDERING
CODES

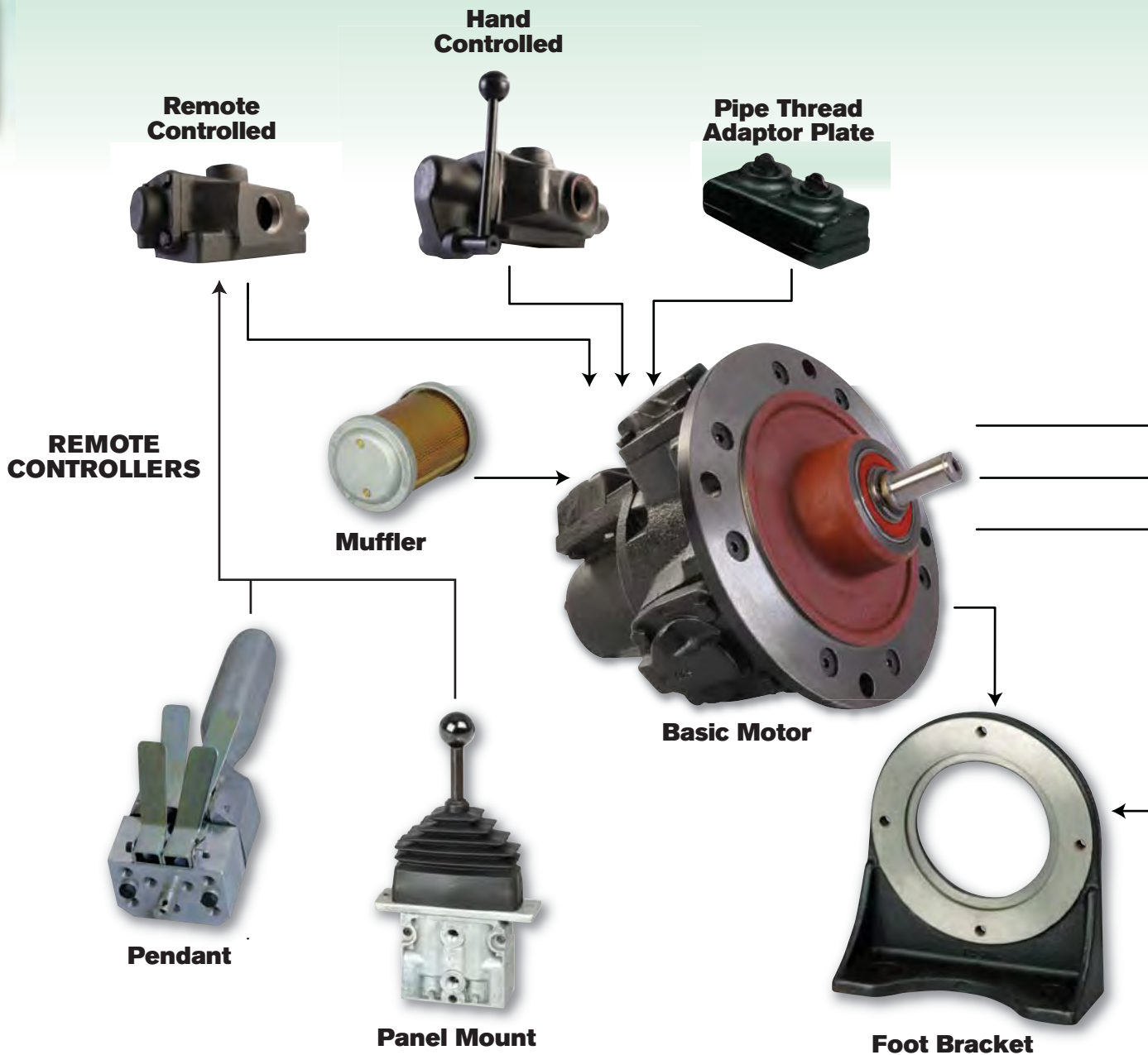

MAINTENANCE

Air Supply

The air filter should be drained regularly and examined for clogging of the element.

The air line lubricator should be replenished as required and set to give:

3-4 drops per minute RM110

4-5 drops per minute RM210

5-6 drops per minute RM310

6-8 drops per minute RM410

6-8 drops per minute RM510

8-10 drops per minute RM610

Double the above drip rate if intermittent operation.

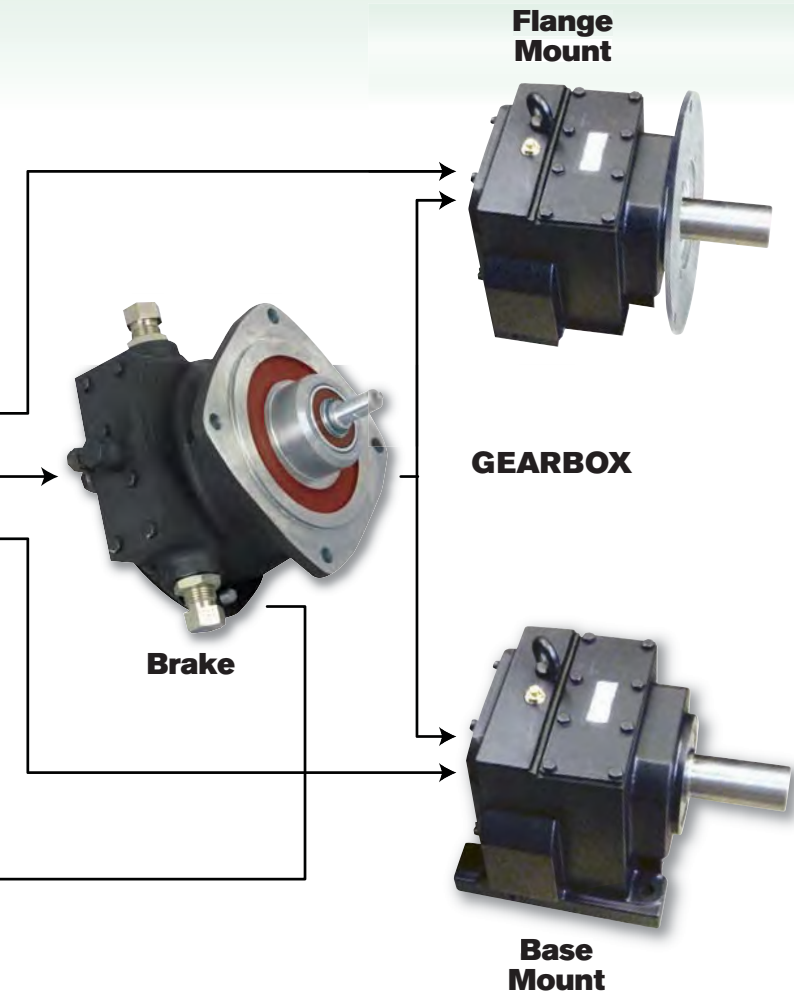

RM110 PEAK POWER 4.7kW (2.4HP) PERFORMANCE DATA

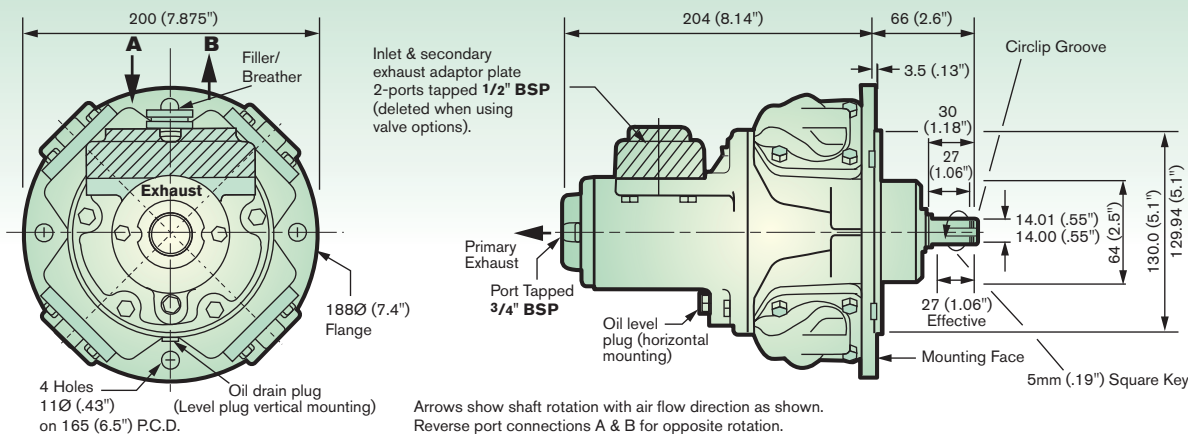

Reading Graphs - Scales have been adjusted to enable bar and psi to be read from a common curve. Therefore only read psi with the left hand axis and bar with the right hand axis.

GRAPH 1 TORQUE - SPEED

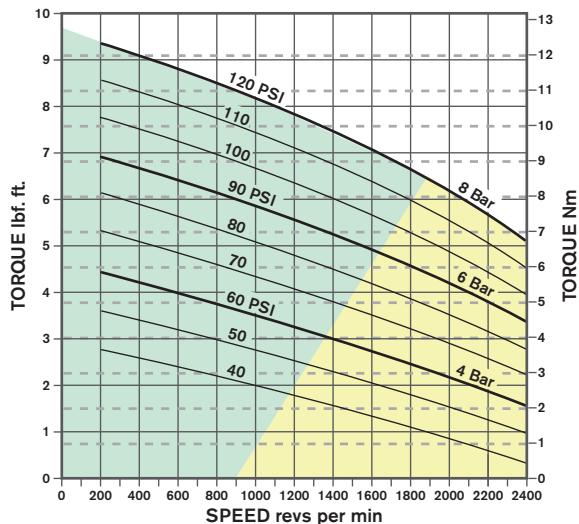

GRAPH 2 STARTING TORQUE - PRESSURE

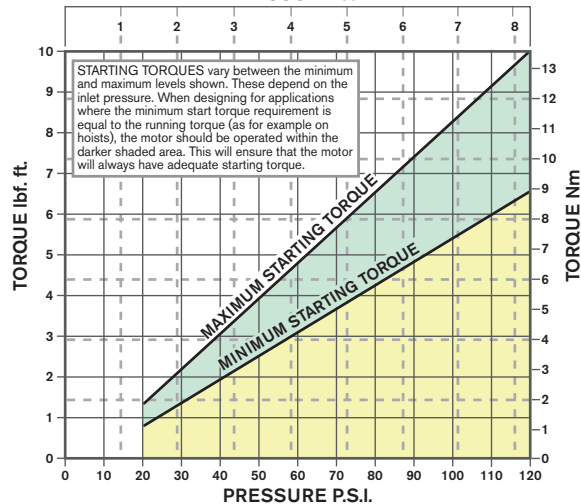

GRAPH 3 POWER - SPEED

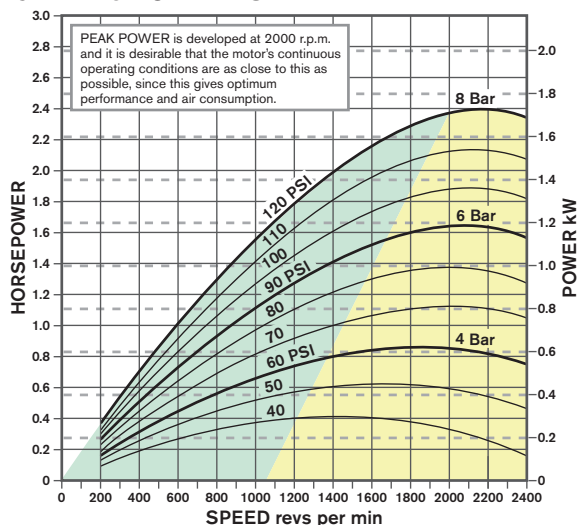

GRAPH 4 CONSUMPTION - SPEED

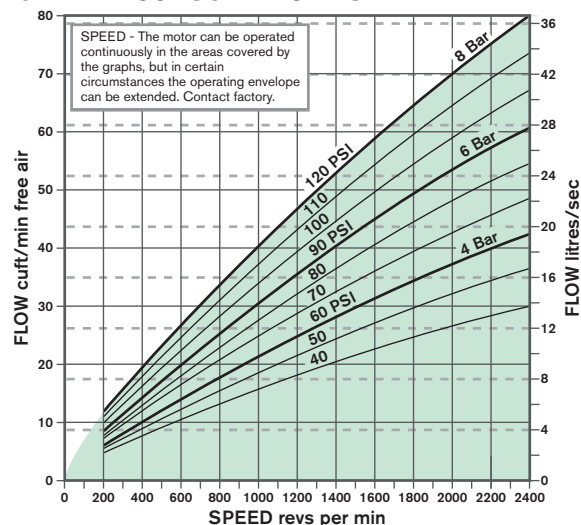

Lubricating Oil Capacities - Horizontal 75 ml / 2.6 fl. oz., Vertical 150 ml / 5.2 fl. oz. Use a good quality hydraulic oil with a viscosity of around 100cSt (460SSU) at 40° C / 104° F.

Airline Filtration and Lubrication - Use 64 micron filtration or better. Choose a lubricator suitable for the flow required. Prior to initial start-up, inject oil into the inlet port. Lubricator drop rate: 3-4 drops/minute continuous operation. Lubrication drop rate 6-10 drop/minute intermittent operation.

General Data -

- Mass** (motor only) 13 kgs / 28.7 lbs.
- Moment of Inertia** of rotating parts 0.01gm² / 0.33 lb. in² (motor only)
- Max Overhung Force** on motor shaft 445 N / 100 lbf.
- Temperature Range** -20° C to +80° C / -4° F to +176° F

RM110 MOTOR SPARE PARTS LIST

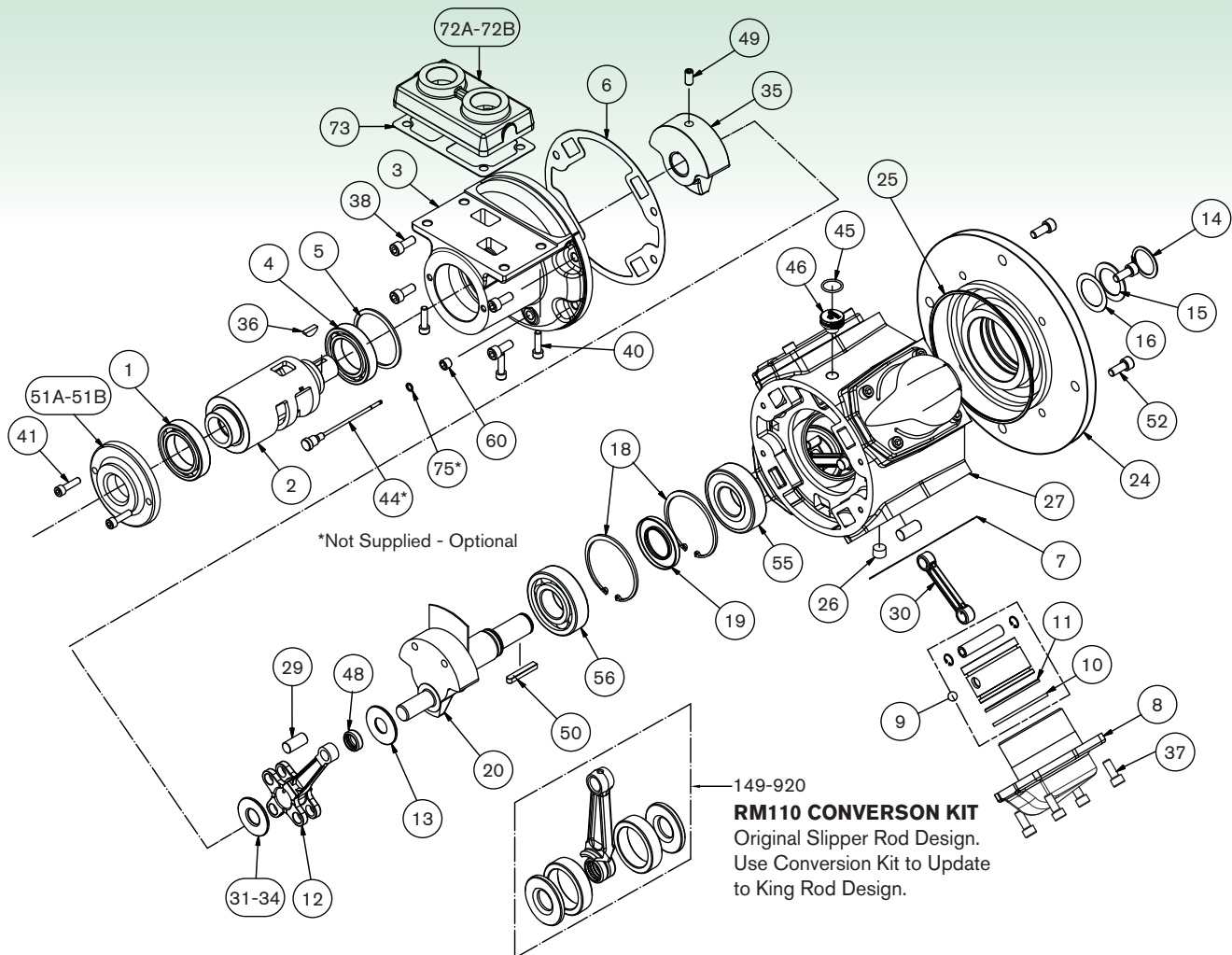

ITEM	PART NO.	DESCRIPTION	QTY.	KIT NO.
1	807-020	Rotary Valve Bearing (Outer)	1	
2	130-006	Rotary Valve	1	
3	130-011	Rotary Valve Housing	1	
4	807-021	Rotary Valve Bearing (Inner)	1	
5	804-051	Rotary Valve Bearing Circlip	1	
6	100-001	Rotary Valve Housing Gasket	1*	139-911
7	110-030	Cylinder Gasket	4*	139-911
8	110-082	Cylinder	4	
9	130-902	Piston Assembly	4	
10	100-024	Compression Ring	4*	139-911
11	100-022	Oil Control Ring	4*	139-911
12	140-077	King Rod	1	
13	140-013	Crankshaft Spacer	1	
14	804-006	Crankshaft Circlip	1	
15	100-035	Crankshaft Spacer	1	
16	100-049	Crankshaft Spacer Shim	5	
18	804-051	Crankshaft Bearing Circlip	2	
19	808-043	Crankshaft Oilseal	1*	139-911
20	110-901	Std. Crankshaft Assembly	1	
24	130-076	Std. Flange Plate	1	
25	808-033	Flange Plate Seal	1*	139-911
26	816-074	Plug	1	
27	130-012	Engine Case	1	
29	140-081	Queen Rod Pivot	3	
30	140-078	Queen Rod	3	
31	140-052	Crank Spacer SELECT	1	149-920
32	140-053	Crank Spacer ON	1	149-920
33	140-054/055	Crank Spacer *ASSEMBLY	1	149-920
34	140-056	Crank Spacer	1	149-920
35	130-010	Balance Weight	1	
36	811-016	Woodruff Key	1	

ITEM	PART NO.	DESCRIPTION	QTY.	KIT NO.
37	802-020	Cylinder Bolts	16	
38	802-020	Valve Housing Bolts	4	
40	802-020	Adaptor Plate Bolt	4	
41	802-016	Exhaust Cover Bolts	2	
44	100-040	Dipstick (vertical mounting)	1	
45	808-004	Seal (transit only)	1	
46	130-066	Breather Plug	1	
48	807-042	Needle Bearing	1	
49	815-012	Grub Screw	1	
50	811-002	Key	1	
51A	130-005	Rotary Valve Exhaust Cover BSP	1	
51B	130-105	Rotary Valve Exhaust Cover NPT	1	
52	810-003	Flange Bolt	8	
55	807-007	Output Shaft Bearing (Outer)	1	
56	807-007	Output Shaft Bearing (Inner)	1	
60	816-063	Oil Level Plug	1	
72A	130-003	Inlet Adaptor Plate BSP	1	
72B	130-103	Inlet Adaptor Plate NPT	1	
73	130-004	Inlet Adaptor Plate Gasket	1*	139-911
75	808-008	Dipstick Seal	1*	139-911
	139-911	Seal Kit	1	
	149-920	Conversion Kit		

Please note item 139-911 (Seal Kit) includes all items marked thus: *
Items marked thus select on assembly.

149-920 CONVERSION KIT

Comprises of items 12, 13, 29, 30, 31-34 and 48. These items may be used to convert a motor from the original design to the king rod design.

If unit is pre 1990 supply contact SPX Hydraulic Technologies to confirm design.

RM110 GEARED MOTOR INSTALLATION DETAILS

Maximum performance details listed below are at 6 bar / 90 psi. The performance under different conditions can be obtained by using the curves on page 6. A typical minimum gearbox efficiency of 90% can be expected. For higher pressures contact SPX Hydraulic Technologies.

The maximum overhung force is assumed acting midway along the output shaft; for other positions or higher loads on intermittent applications; contact SPX Hydraulic Technologies.

PERFORMANCE SUMMARY

GEARBOX RATIO	MAXIMUM POWER CONDITIONS						APPROX. MIN. START TORQUE		MAX. CONT. rmp	MAX. OVERHUNG FORCE		WEIGHT			
	kW	hp	rpm	TORQUE		Nm	lbf. ft	N		lbf.	GEARBOX	ADAPTER	GEARBOX KIT	MOTOR & GEARBOX	
				Nm	lbf. ft										
4.77	1.2	1.6	440	23	17	28	20	498	1020	229	15.5	4.5	20	33	
24.50	1.2	1.6	86	122	90	146	108	97	1990	447	15.5	4.5	20	33	
50.00	1.2	1.6	42	250	185	300	221	48	4150	933	26	4.5	30.5	43.5	
73.30	1.2	1.6	29	366	270	439	324	32	7690	1729	45	4.5	49.5	62.5	
104.80	1.2	1.6	20	524	387	629	464	23	10820	2433	45	4.5	49.5	62.5	
129.79	1.2	1.6	16	649	479	779	575	18	18925	4255	79	4.5	83.5	96.5	
155.46	1.2	1.6	14	777	573	932	688	15	18925	4255	79	4.5	83.5	96.5	
175.18	1.2	1.6	12	876	646	1051	776	14	18925	4255	79	4.5	83.5	96.5	
213.64	1.2	1.6	10	1068	788	1282	946	11	18925	4255	79	4.5	83.5	96.5	
256.86	1.2	1.6	8	1284	948	1541	1137	9	23515	5287	129	4.5	133.5	146.5	

For additional types and ratios contact SPX Hydraulic Technologies.

BASE MOUNTED GEAR BOX DIMENSIONS

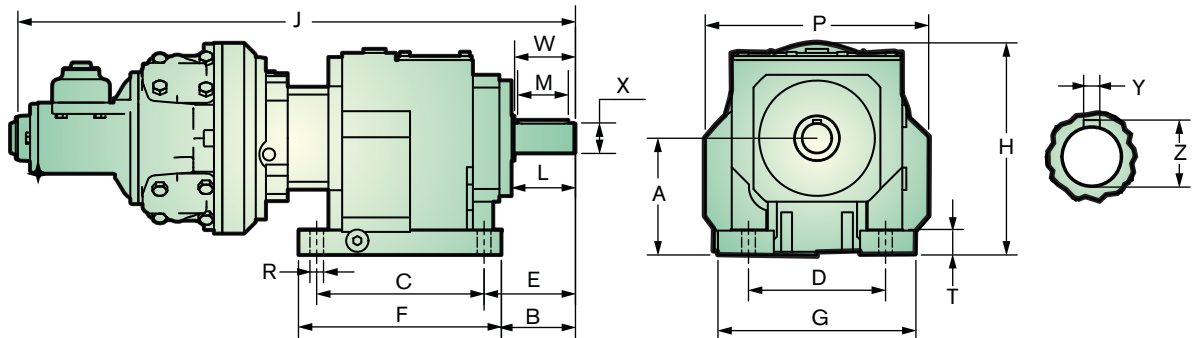

RANGE RATIO	A	B	C	D	E	F	G	H	J	L	M	P	R	T	W	X	Y	Z	MASS
4.77 - 24.5:1	90+4.00	60	130	110	75	160	145	184+4	495	53	40	188	9.8	20	50	25.01	8.00	28	33 kg
	3.5"+0.2"	2.4"	5.1"	4.3"	3.0"	6.3"	5.7"	7.4"+0.2"	19.5"	2.1"	1.6"	7.4"	0.4"	0.8"	2.0"	.98"	0.3"	1.1"	72.5 lb
27 - 56:1	115	75	165	135	90	200	195	209	532	63	50	220	13.5	25	60	30.01	8.00	33	42 kg
	4.5"	3.0"	6.5"	5.3"	3.5"	7.9"	7.7"	8.2"	20.9"	2.5"	2.0"	8.7"	0.5"	1.0"	2.4"	1.18"	0.3"	1.3"	92.5 lb
56 - 61:1	115	75	165	135	90	200	195	209	532	63	50	220	13.5	25	60	30.01	8.00	33	43.5 kg
	4.5"	3.0"	6.5"	5.3"	3.5"	7.9"	7.7"	8.2"	20.9"	2.5"	2.0"	8.7"	0.5"	1.0"	2.4"	1.18"	0.3"	1.3"	96 lb
60 - 88.59:1	140	95	205	170	115	245	235	290	601	84	70	263	17.5	30	80	40.01	12	43	62.5 kg
	5.5"	3.7"	8.1"	6.7"	4.5"	9.6"	9.3"	11.4"	23.7"	3.3"	2.8"	10.4"	0.7"	1.2"	3.1"	1.58"	0.5"	1.7"	137 lb

FLANGE MOUNTED GEAR BOX DIMENSIONS

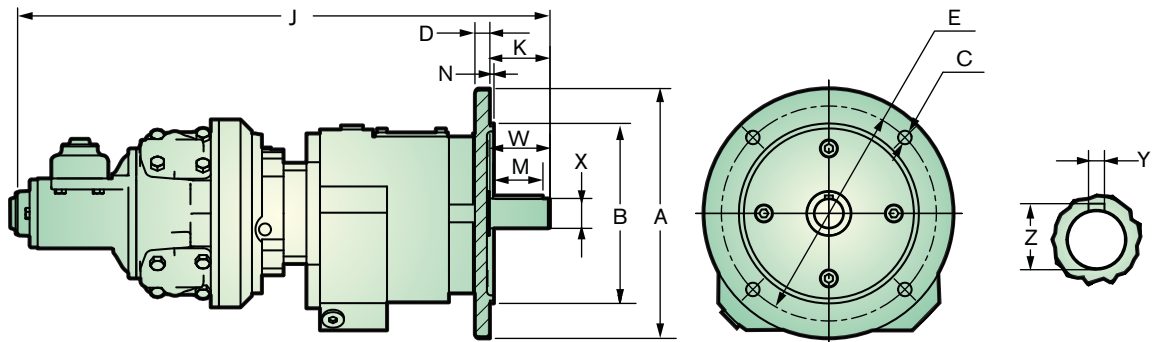

RANGE RATIO	A	B	C	D	E	J	K	M	N	W	X	Y	Z	MASS
4.77 - 24.5:1	200	130.00	11	12	165	495	50	40	3.5	50	25.01	8.00	28	33 kg
	7.9"	5.12"	0.4"	0.47"	6.5"	19.5"	2.0"	1.6"	0.1"	2.0"	.98"	0.3"	1.1"	72.5 lb
27 - 56:1	250	180	13.5	15	215	532	60	50	4	60	30.01	8.00	33	42 kg
	9.8"	7.09"	0.5"	0.6"	8.5"	20.9"	2.4"	2.0"	0.2"	2.4"	1.18"	0.3"	1.3"	92.5 lb
56 - 61:1	250	180	13.5	15	215	532	60	50	4	60	30.01	8.00	33	43.5 kg
	9.8"	7.09"	0.5"	0.6"	8.5"	20.9"	2.4"	2.0"	0.2"	2.4"	1.18"	0.3"	1.3"	96 lb
60 - 88.59:1	300	230.05	13.5	16	265	610	80	70	4	80	40.01	12.0	43	62.5 kg
	11.8"	9.06"	0.5"	0.6"	10.4"	24.0"	3.1"	2.8"	0.2"	3.1"	1.58"	0.5"	1.7"	137 lb

Detailed drawings and CAD models available on request. Ratios above the basic range shown are available on request. Alternative gearbox types and arrangements i.e. right angle output, hollow shaft etc. also available.

Modified dimensions for shafts and flanges available on request.

RM110 VALVE OPTIONS

This range of bolt on valves offers very sensitive speed and directional control. One frictionless matched spool and sleeve assembly is offered with two alternative means of actuation.

CONFIGURATION

As standard these valves can be supplied with either EQUAL POWER or BIASED POWER spools, the latter is suitable for hoisting applications (normal power for lifting - reduced power for lowering).

The direction of reduced power must be stated when ordering CW or CCW, when viewed on the output shaft of the motor or geared motor.

1. Remotely Controlled (RCV) - This option is usually controlled from a remote position by one of the PC series or LC2 units. A variable air pilot signal is

applied to either end of the valve spool, depending on the required direction of motor rotation. The pilot pressure range is between 1.4 bar / 20 psi and 4.8 bar / 70 psi, increased pilot pressure give increased speed. The valve is spring centered to neutral.

2. Hand Controlled (HCV) - The control valve spool is operated directly by a lever mechanism. Speed increase is obtained as the lever is moved in either direction from the center (neutral) position.

Pressure Drop - Minimal pressure drop will be experienced through the valves, having the effect of maintaining the output torque while reducing the motor output speed by approximately 10-15% at 6 bar / 90 psi at maximum power. The starting torque remains unaffected.



REMOTE CONTROL VALVE - 1/2 BSP PORTS

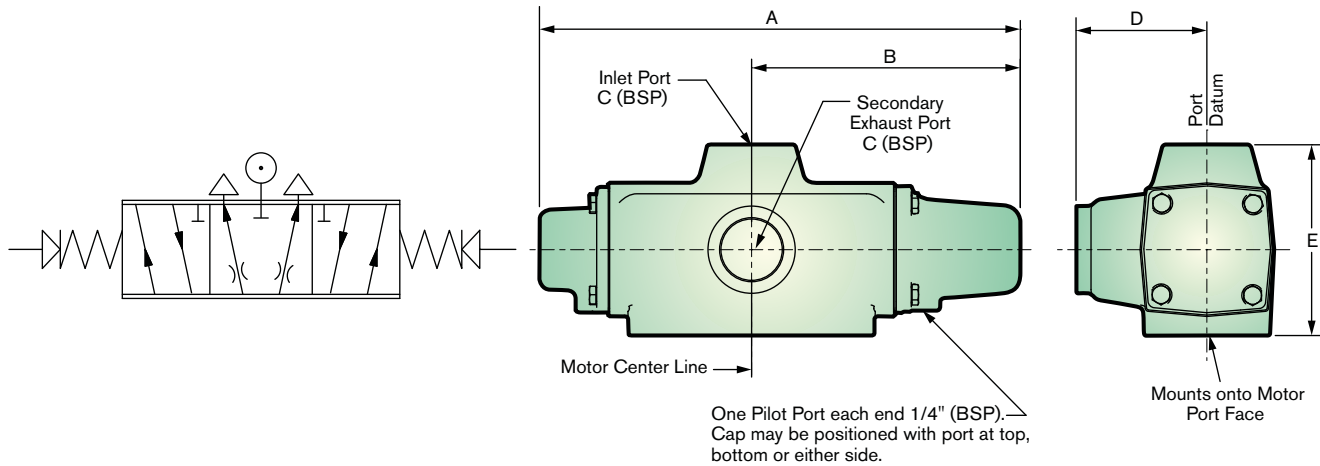

Modified threads and other valve options are available upon request. Please contact SPX Hydraulic Technologies.

A	B	C (BSP)	D	E	Approx. WT.
210.8	118.1	1/2	60.9	83.8	4.03 kg
8.3"	4.65"		2.4"	3.3"	8.9 lbs.

HAND CONTROL VALVE - 1/2 BSP PORTS

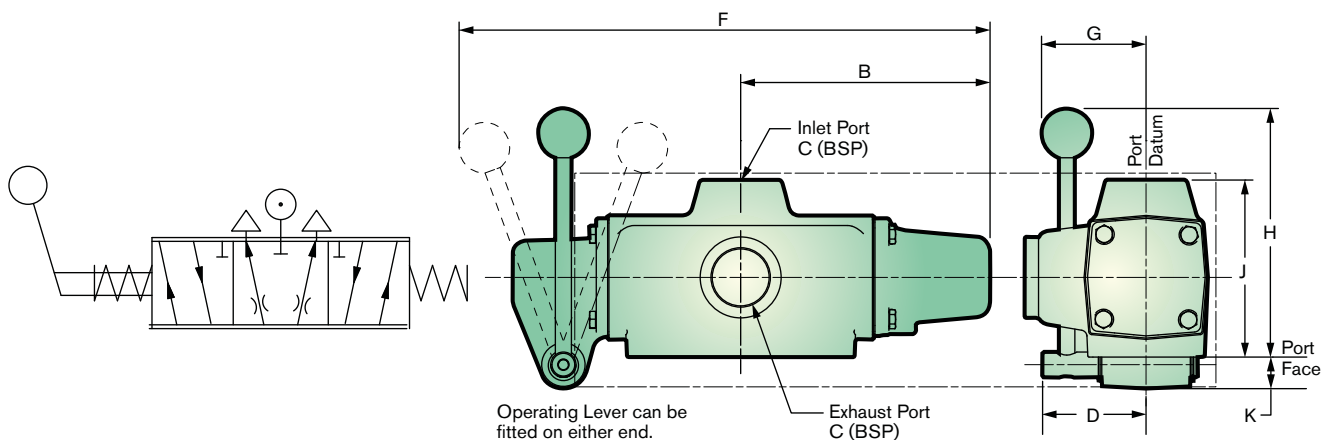

Modified threads and other valve options are available upon request. Please contact SPX Hydraulic Technologies.

B	C (BSP)	D	F	G	H	J	K	Approx. WT.
118.1	1/2	60.9	269.2	60.9	162.5	83.8	21.0	4.03 kg
4.65"		2.4"	10.6"	2.4"	6.4"	3.3"	0.83"	8.9 lbs.

RM110 VALVE OPTIONS SPARE PARTS LISTS

REMOTE CONTROL VALVE - 1/2 BSP PORTS

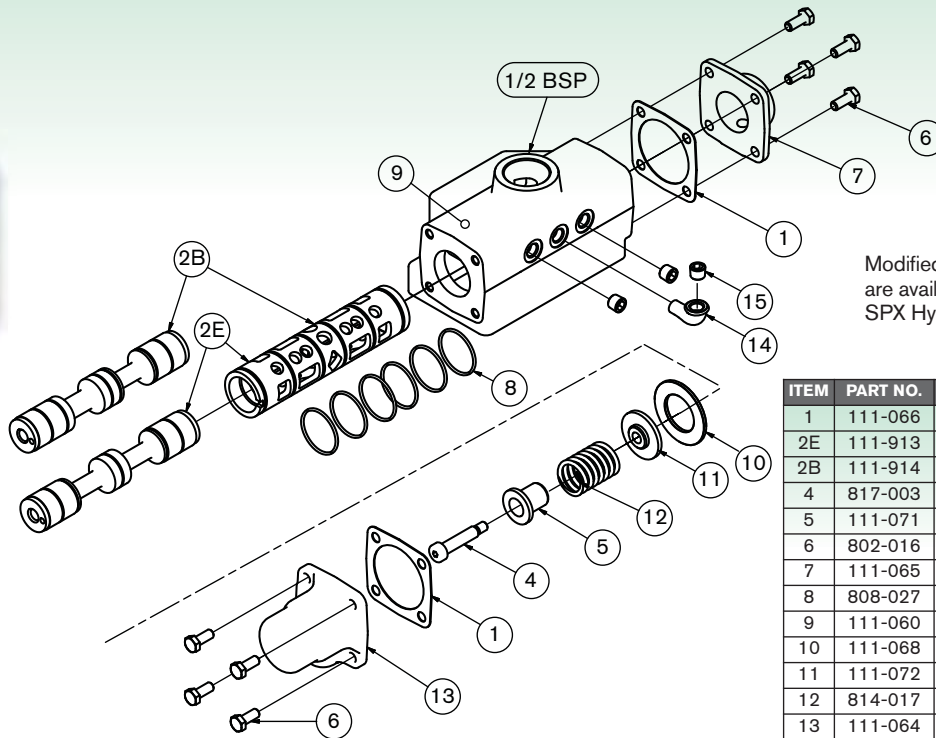

Modified threads and other valve options are available upon request. Please contact SPX Hydraulic Technologies.

ITEM	PART NO.	DESCRIPTION	QTY.
1	111-066	End Cap Gasket	2
2E	111-913	Matched Spool and Sleeve (Equipower)	1
2B	111-914	Matched Spool and Sleeve (Biased)	1
4	817-003	Shoulder Screw 8mm	1
5	111-071	Centering Shaft Guide	1
6	802-016	Hex Head Screw M6 x 16	8
7	111-065	End Cap - Plain End	1
8	808-027	O-Ring 27, 5 x 30	6
9	111-060	Valve Body	1
10	111-068	Valve Sleeve Spacer	1
11	111-072	Washer, Spring Centering	1
12	814-017	Spring D13040	1
13	111-064	End Cap - Spring End	1
14	816-049	Elbow M/F 1/8" BSPT	1
15	816-063	Plug 1/8" BSPT	3

HAND CONTROL VALVE - 1/2 BSP PORTS

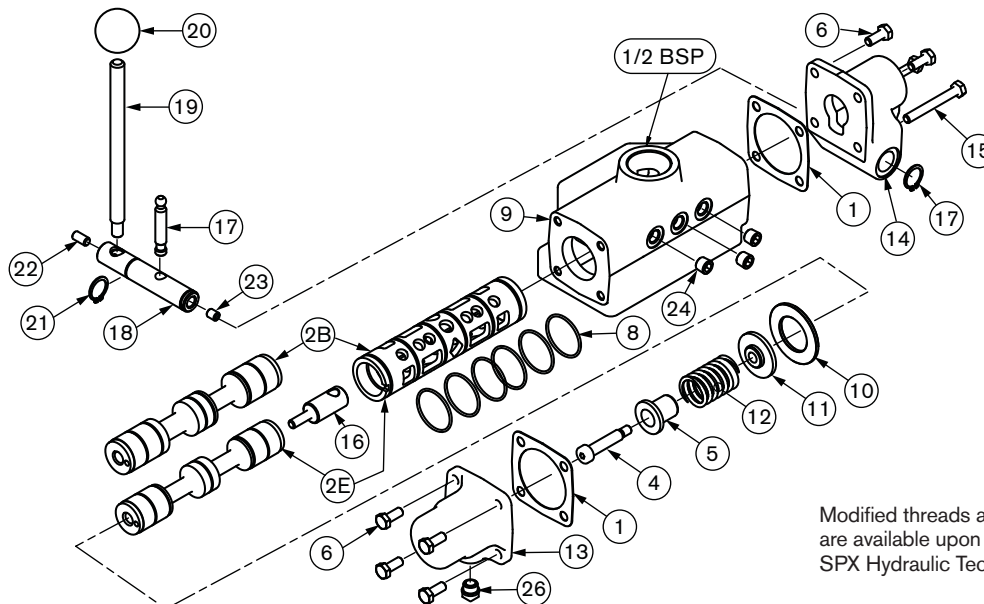

Modified threads and other valve options are available upon request. Please contact SPX Hydraulic Technologies.

ITEM	PART NO.	DESCRIPTION	QTY.
1	111-066	End Cap Gasket	2
2E	111-913	Matched Spool and Sleeve (Equipower)	1
2B	111-914	Matched Spool and Sleeve (Biased)	1
4	817-003	Shoulder Screw 8mm	1
5	111-071	Centering Shaft Guide	1
6	802-016	Hex Head Screw M6 x 16	8
8	808-027	O-Ring 27, 5 x 30	6
9	111-060	Valve Body	1
10	111-068	Valve Sleeve Spacer	1
11	111-072	Washer, Spring Centering	1
12	814-016	Spring 323714	1
13	111-064	End Cap - Spring End	1

ITEM	PART NO.	DESCRIPTION	QTY.
14	113-041	Hand Lever Cap	1
15	802-024	Hex Head Bolot M6 x 50	2
16	113-024	Toggle Shaft	1
17	113-026	Toggle Pin	1
18	113-008	Hand Lever Pivot	1
19	313-002	Hand Lever	1
20	818-002	Black Plastic Knob 31mm	1
21	804-013	Circlip 20mm External	2
22	515-010	Grub Screw M8 x 10	1
23	815-022	Grub Screw M8 x 16	1
24	816-063	Plug 1/8" BSPT	3
26	113-050	Vent Plug	1

RM110 PARKING BRAKE INSTALLATION DETAILS

The brake module bolts directly onto the motor mounting face and has exactly the same interface as the motor. As shown on the drawing below, the brake consists of two spring applied shoes pressed against a central hub. These shoes are released by applying air pressure to the cylinder/piston assembly. The brake torque can be varied by means of two spring adjusters

but it is normally set so that a pilot pressure of 4.1 bar / 60 psi will fully release it. Pressures below this level will progressively reduce the braking torque available. The brakes are set at the plant but it may be necessary to make adjustments on site to suit the individual application.

BRAKE VIEW

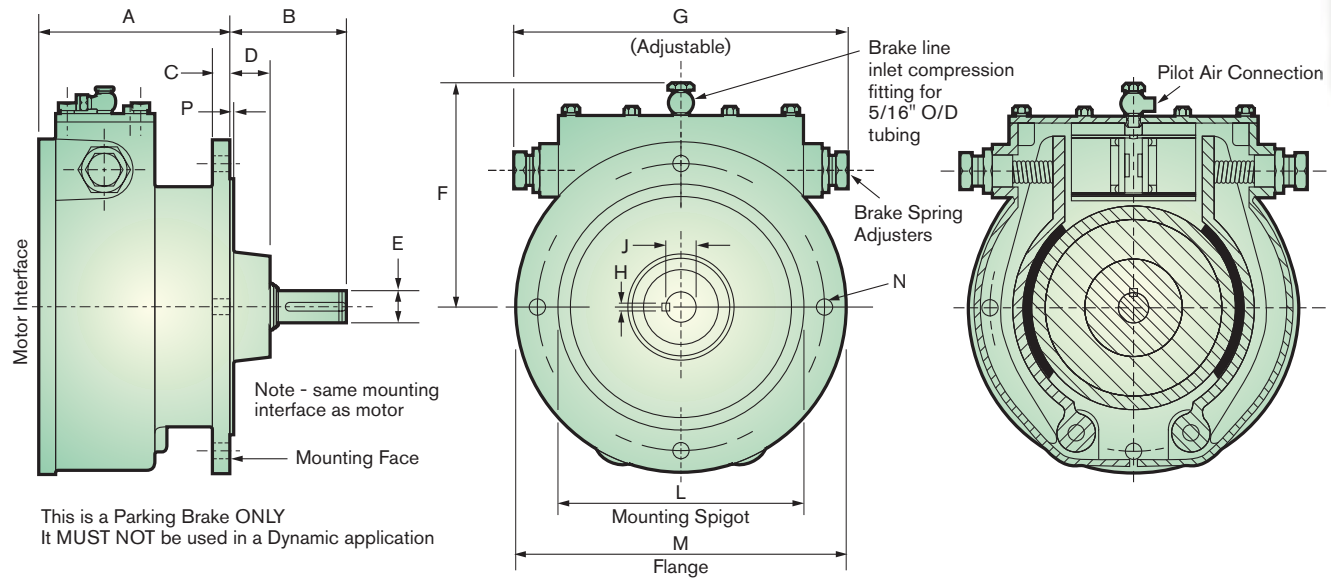

A	B	C	D	E	F	G	P	H	J	L	M	N-MOUNTING HOLES			
												NO.	Ø	P.C.D.	BOLT LENGTH (MAX)
99.0	66.0	10.9	30.4	13.9	127.0	210.8	3.5	5.0	15.7	129.5	187.9	101.6	10.9	165.1	28.5
3.9"	2.6"	0.43"	1.2"	0.5515"	5.0"	8.3"	0.14"	0.197"	0.6275"	5.117"	7.4"	4"	0.43"	6.5"	1-1/8"

CIRCUITS

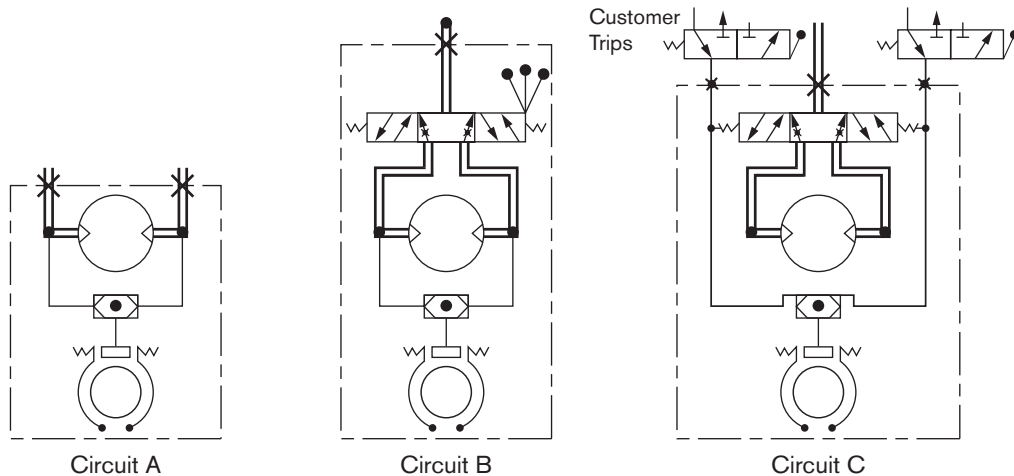

Circuit (A) - Applies to braked motors supplied without control valving. The unit will be fitted with a shuttle valve to allow brake operation for dual rotation.

Circuit (B) - Units supplied with hand (HCV) controlled reversible valves. If trips are required they must be of the mechanical style (customer's supply).

Circuit (C) - Units supplied with remotely controlled valves. When override trips are required, they must be superimposed in the signal line close to the motor unit and be of the 3 way style. (Signal lines cut and exhausted in the tripped position.)

RM110

PARKING BRAKE SPARE PARTS LIST & FOOT BRACKET

PARKING BRAKE SPARE PARTS LIST

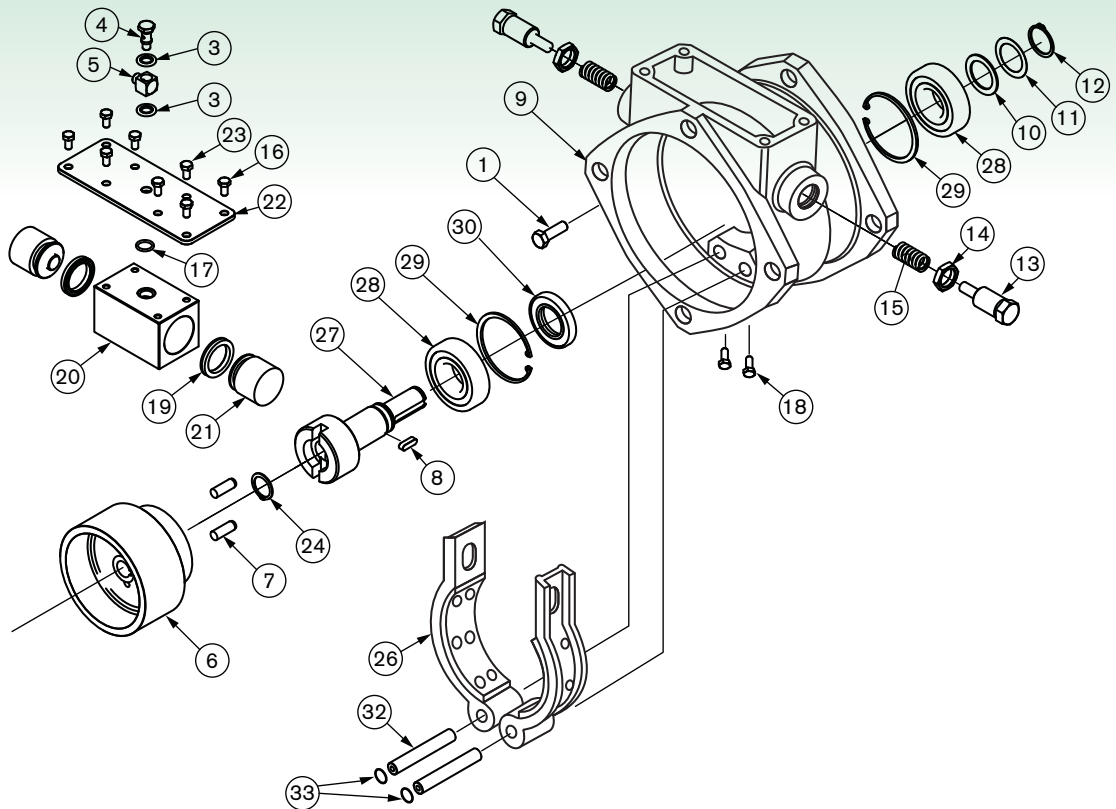

ITEM	PART NO.	DESCRIPTION	QTY.
1	802-052	Set Screw M10 x 20	4
3	808-090	Bonded Seal 1/4" BSP Dowty	2
4	816-004	Banjo Bolt Only 1/8" BXP	1
5	816-005	Banjo Body C/W Nut & Pin 5/16"	1
6	112-001	Brake Wheel	1
7	806-001	Dowel Diameter 10 x 30 Lg	2
8	811-022	Key K123 5Sq	1
9	112-008	Brake Housing	1
10	100-049	Shim - Output	5
11	100-035	Output Shaft Spacer	1
12	804-006	Circlip 19mm External	1
13	102-009	Brake Spring Adjuster	2
14	102-024	1/2" BSP Hex Nut	2
15	814-002	Spring 223612	2
16	802-016	Hex Head Screw M6 x 16	4

ITEM	PART NO.	DESCRIPTION	QTY.
17	112-030	Piston Block O-Ring	1
18	802-020	Hex Head Screw M6 x 20	2
19	808-072	U Packing U110	2
20	112-014	Piston Block	1
21	102-011	Brake Piston	2
22	112-013	Block Support Plate	1
23	802-012	Hex Head Screw M6 x 12	2
24	804-003	Circlip 14mm External	1
26	112-901	Brake Shoe Assembly	2
27	112-005	Output Shaft	1
28	807-007	Ball Bearing	2
29	804-051	Circlip 47mm Internal	2
30	808-043	Ollseal 20x47x10/R4	1
32	112-003	Brake Shoe Pivot	2
33	804-121	Circlip 3/8" External Ander	2

FOOT BRACKET

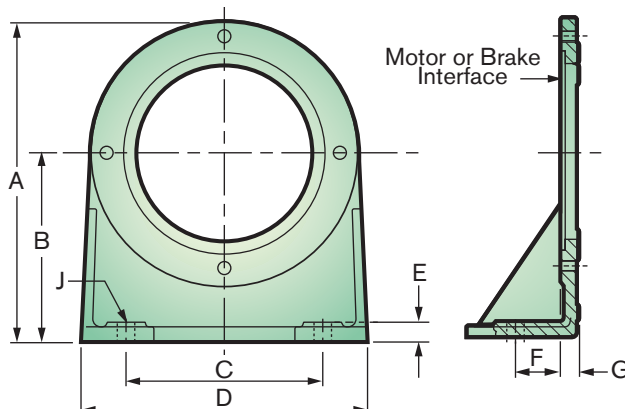

A	B	C	D	E	F	G	H	J
124.7	124.7	140	203.2	10.1	32.0	15.2	-	2 x Ø 13.9
8.7"	4.9"	5.5"	8.0"	0.4"	1.26"	0.6"	-	2 x Ø 0.55"

RM210

PEAK POWER 4kW (5.5HP) PERFORMANCE DATA

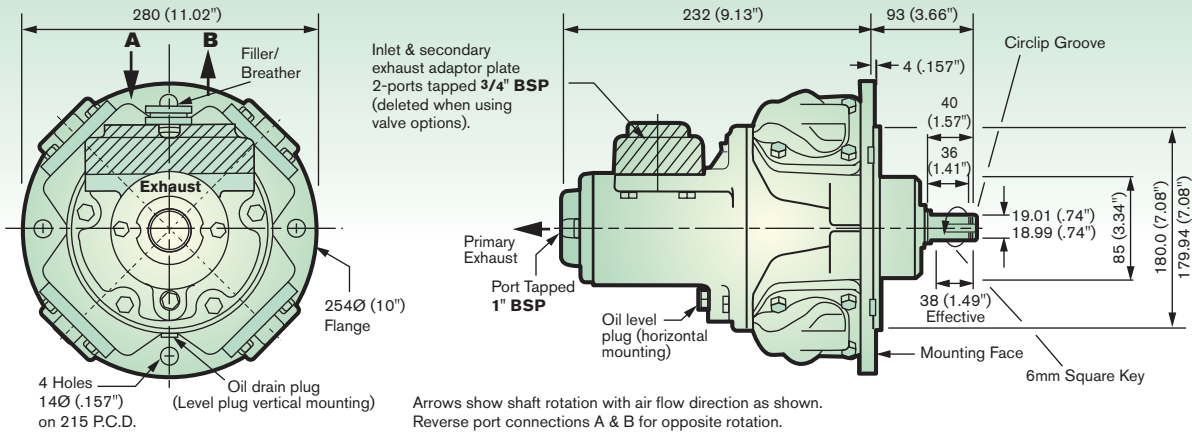

Reading Graphs - Scales have been adjusted to enable bar and psi to be read from a common curve. Therefore only read psi with the left hand axis and bar with the right hand axis.

GRAPH 1 TORQUE - SPEED

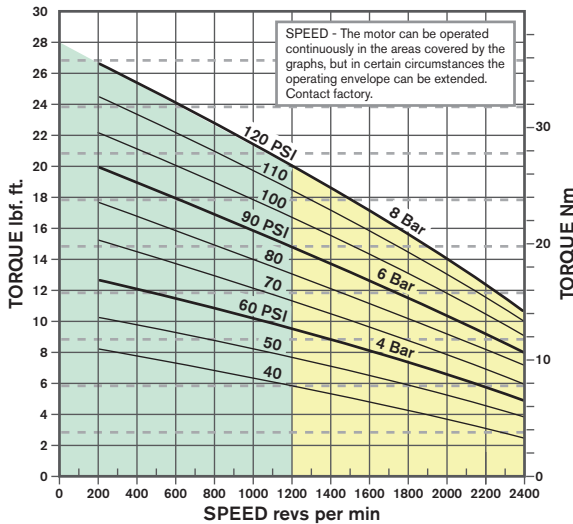

GRAPH 2 STARTING TORQUE - PRESSURE

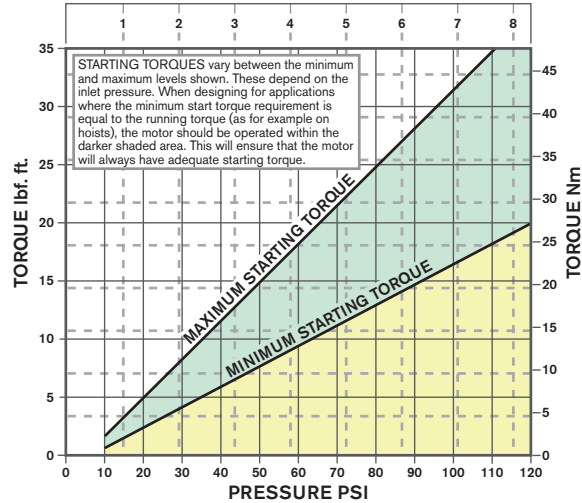

GRAPH 3 POWER - SPEED

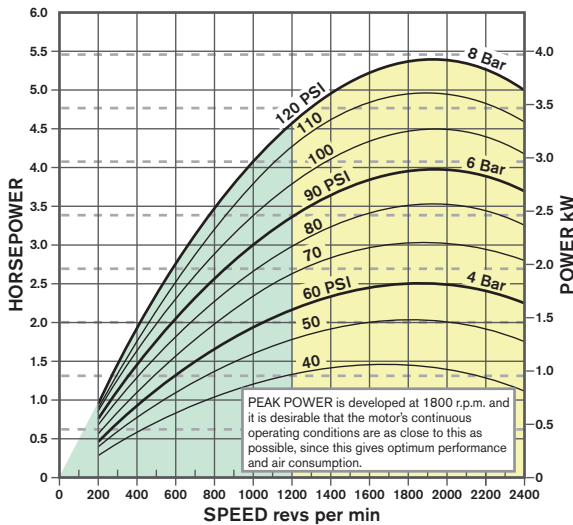

GRAPH 4 CONSUMPTION - SPEED

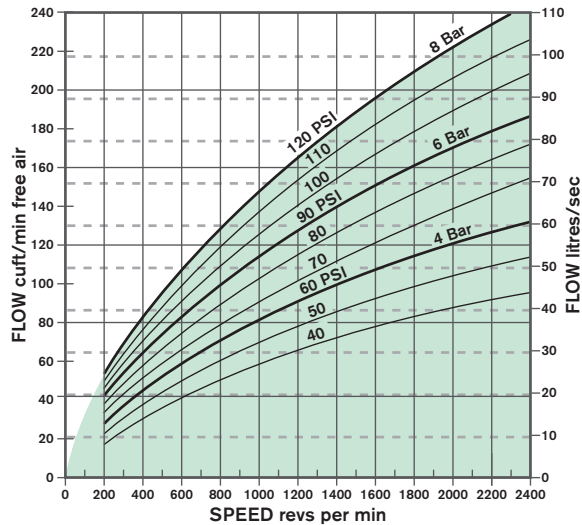

Lubricating Oil Capacities - Horizontal 330 ml / 10.5 fl. oz., Vertical 450 ml / 15.5 fl. oz. Use a good quality hydraulic oil with a viscosity of around 100cSt (460SSU) at 40° C / 104° F.

Airline Filtration and Lubrication - Use 64 micron filtration or better. Choose a lubricator suitable for the flow required. Prior to initial start-up, inject oil into the inlet port. Lubricator drop rate: 3-4 drops/minute continuous operation. Lubricator drop rate 6-10 drop/minute intermittent operation.

General Data -

Mass (motor only) 26 kgs / 57.3 lbs.

Moment of Inertia of rotating parts 56 gm² / 1.9 lb. in² (motor only)

Max Overhung Force on motor shaft 890 N / 200 lbf.

Temperature Range -20° C to +80° C / -4° F to +176° F



RM210 MOTOR SPARE PARTS LIST

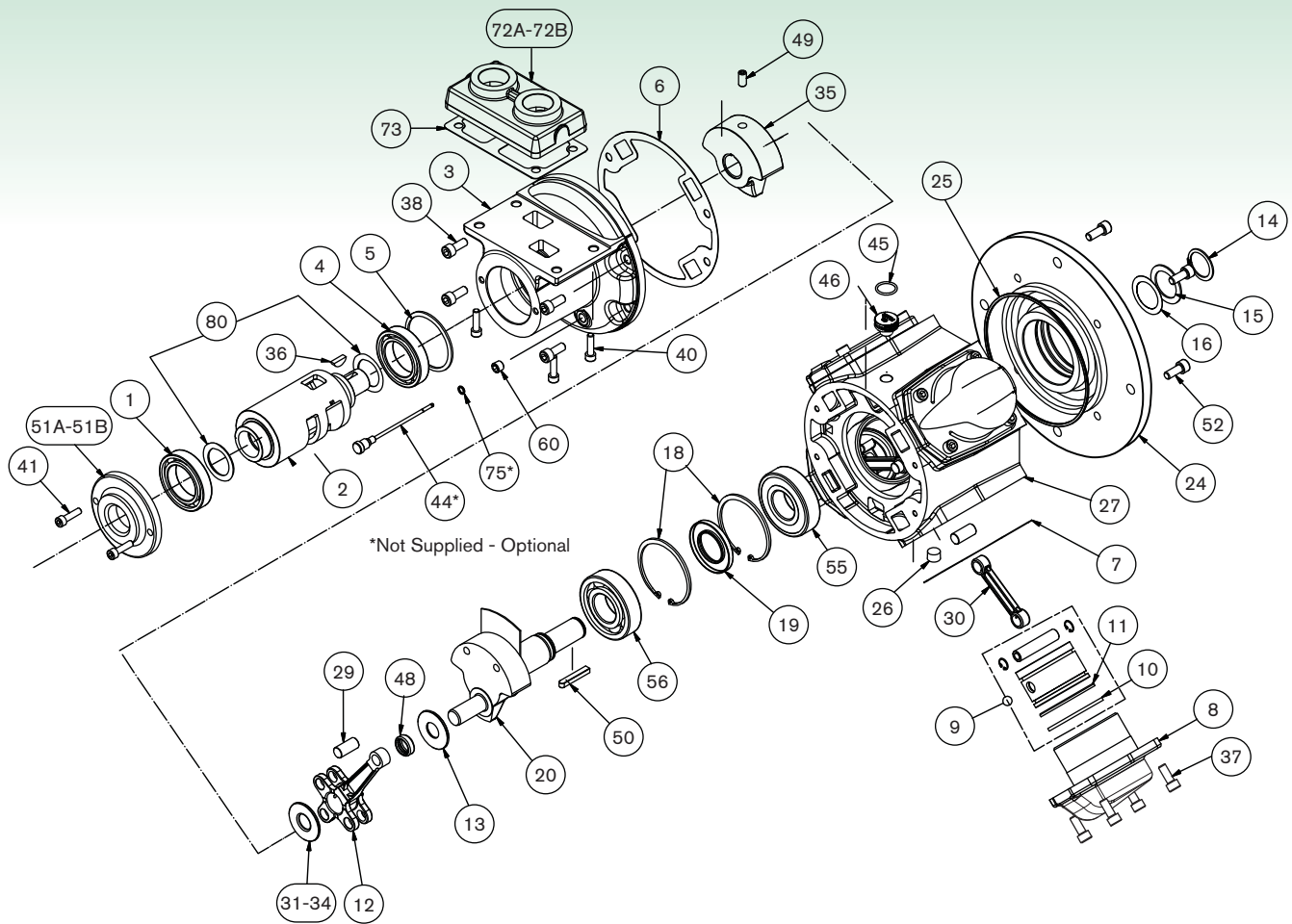

ITEM	PART NO.	DESCRIPTION	QTY.	KIT NO.
1	807-020	Rotary Valve Bearing (Outer)	1	
2	230-059	Rotary Valve	1	
3	230-011	Rotary Valve Housing	1	
4	807-021	Rotary Valve Bearing (Inner)	1	
5	804-051	Rotary Valve Bearing Circlip	1	
6	200-001	Rotary Valve Housing Gasket	1*	239-911
7	210-030	Cylinder Gasket	4*	239-911
8	210-082	Cylinder	4	
9	230-902A	Piston Assembly	4	
10	200-024	Compression Ring	4*	239-911
11	200-022	Oil Control Ring	4*	239-911
12	230-077	King Rod	1	
13	230-013	Crankshaft Spacer	1	
14	804-009	Crankshaft Circlip	1	
15	300-035	Crankshaft Spacer	1	
16	300-049	Crankshaft Spacer Shim	5	
18	804-058	Crankshaft Bearing Circlip	2	
19	808-044	Crankshaft Oilseal	1*	239-911
20	230-915	Std. Crankshaft Assembly	1	
24	230-076	Std. Flange Plate	1	
25	808-028	Flange Plate Seal	1*	239-911
26	816-071	Plug	1	
27	230-012	Engine Case	1	
29	230-081	Queen Rod Pivot	3	
30	230-078	Queen Rod	3	
31	230-052	Crank Spacer SELECT	1	
33	230-054/055	Crank Spacer ASSEMBLY	1	
34	230-056	Crank Spacer	1	

ITEM	PART NO.	DESCRIPTION	QTY.	KIT NO.
35	230-010	Balance Weight	1	
36	811-010	Woodruff Key	1	
37	802-032	Cylinder Bolts	16	
38	802-033	Valve Housing Bolts	4	
40	802-020	Adaptor Plate Bolt	4	
41	802-016	Exhaust Cover Bolts	2	
44	200-040	Dipstick (Vertical Mounting)	1	
45	808-004	Seal (Transit Only)	1	
46	130-066	Breather Plug	1	
48	807-048	Needle Bearing	1	
49	815-001	Grub Screw	1	
50	811-001	Key	1	
51A	230-005	Rotary Valve Exhaust Cover BSP	1	
51B	230-105	Rotary Valve Exhaust Cover NPT	1	
52	810-001	Flange Bolts	8	
55	807-007	Output Shaft Brg. (Outer)	1	
56	807-008	Output Shaft Brg. (Inner)	1	
60	816-063	Oil Level Plug	1	
72A	230-003	Inlet Adaptor Plate BSP	1	
72B	230-103	Inlet Adaptor Plate NPT	1	
73	130-004	Inlet Adaptor Plate Gasket	1*	239-911
75	808-008	Dipstick Seal	1*	239-911
	239-911	Seal Kit	1	
80	230-060	Rotary Valve Spacer	2	

Please note item 239-911 (Seal Kit) includes all items marked thus:*
Items marked thus select on assembly.

RM210 GEARED MOTOR INSTALLATION DETAILS

Maximum performance details listed below are at 6 bar / 90 psi. The performance under different conditions can be obtained by using the curves on page 15. A typical minimum gearbox efficiency of 90% can be expected. For higher pressures contact SPX Hydraulic Technologies.

The maximum overhung force is assumed acting midway along the output shaft; for other positions or higher loads on intermittent applications; contact SPX Hydraulic Technologies.

PERFORMANCE SUMMARY

GEARBOX RATIO	MAXIMUM POWER CONDITIONS						APPROX. MIN. START TORQUE	MAX. CONT.	MAX. OVERHUNG FORCE			WEIGHT			
	kW	hp	rpm	TORQUE		rmp			N	lbf.	GEARBOX	ADAPTER	GEARBOX KIT	MOTOR & GEARBOX	
				Nm	lbf. ft										
5.15	3	4	369	77	57	93	68	461	2350	528	30	10	40	66	
25.55	3	4	74	383	283	460	339	93	3380	760	47	10	57	83	
49.42	3	4	38	741	547	890	657	48	14060	3161	79	10	89	115	
74.88	3	4	25	1123	829	1348	995	32	16330	3671	79	10	89	115	
105.08	3	4	18	1576	1163	1891	1396	23	20860	4690	129	10	139	165	
126.90	3	4	15	1904	1405	2284	1686	19	23515	5287	129	10	139	165	
148.99	3	4	13	2235	1649	2682	1979	16	26070	5861	194	10	204	230	
171.62	3	4	11	2574	1900	3089	2280	14	31220	7019	194	10	204	230	
201.22	3	4	9	3018	2228	3622	2673	12	36770	8267	194	10	204	230	
254.70	3	4	7	3821	2820	4585	3383	9	38930	8752	312	10	322	348	

For additional types and ratios contact SPX Hydraulic Technologies.



BASE MOUNTED GEAR BOX DIMENSIONS

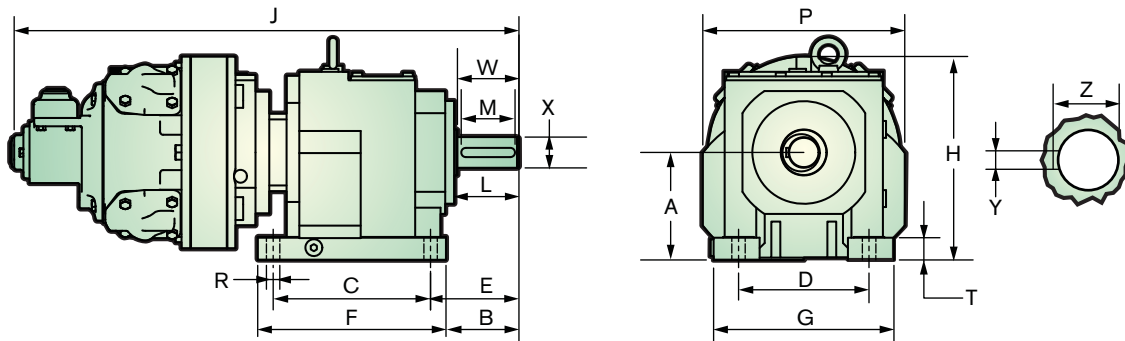

RANGE RATIO	A	B	C	D	E	F	G	H	J	L	M	P	R	T	W	X	Y	Z	MASS
4.28 - 20.95:1	115 + 10.00	75	165	135	90	200	195	250	607	63	50	250	13.5	25	60	30.01	8.00	33	65.5 kg
	4.5"+0.4"	3.0"	6.5"	5.3"	3.5"	7.9"	7.7"	9.8"	23.9"	2.5"	2.0"	9.8"	0.5"	1.0"	2.4"	1.18"	0.3"	1.3"	144 lb
21.76 - 34.49:1	140	96	205	170	115	245	235	290	657	84	70	263	17.5	30	80	40.01	12.0	43	82.5 kg
	5.5"	3.8"	8.1"	6.7"	4.5"	9.6"	9.3"	11.4"	25.9"	3.3"	2.8"	10.4"	0.7"	1.2"	3.1"	1.58"	0.5"	1.7"	182 lb
41.19 - 74.88:1	180	115	260	215	140	310	290	364	764	104	80	332	17.5	45	100	50.01	14	53.50	115 kg
	7.1"	4.5"	10.2"	8.5"	5.5"	12.2"	11.4"	14.3"	30.1"	4.1"	3.1"	13.1"	0.7"	1.8"	3.9"	1.97"	0.6"	2.1"	254 lb
82.14 - 126.9:1	225	132	310	250	160	365	340	445	810	125	100	410	22	50	120	60.02	18	64	165 kg
	8.9"	5.19"	12.2"	9.8"	6.3"	14.4"	13.4"	17.5"	27.0"	4.9"	4.9"	16.1"	0.9"	2.0"	4.7"	2.36"	0.7"	2.5"	364 lb

FLANGE MOUNTED GEAR BOX DIMENSIONS

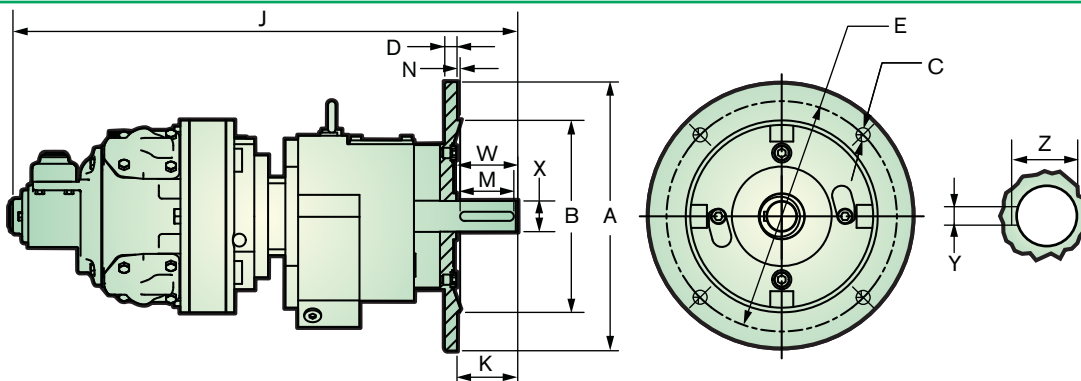

RANGE RATIO	A	B	C	D	E	J	K	M	N	W	X	Y	Z	MASS
4.28 - 20.95:1	250	180.00	13.5	15	215	607	60	50	4	60	30.015	8.0	33	65.5 kg
	9.8"	7.1"	0.5"	0.6"	8.5"	23.9"	2.4"	2.0"	0.2"	2.4	1.18"	0.3"	1.3"	144 lb
21.76 - 34.49:1	350	250.00	17.5	16	300	658	80	70	4	80	40	12	43	82.5 kg
	13.8"	9.8"	0.7"	.62	11.8"	25.9"	3.1"	2.8"	0.2"	3.1"	1.58"	0.5	1.7"	182 lb
41.19 - 74.88:1	350	250.00	17.5	18	300	743	100	80	5	100	50.01	14	53.5	114.5 kg
	13.8"	9.8"	0.7"	0.7	11.8"	29.3"	3.9"	3.1"	0.2"	3.9"	1.97"	0.6"	2.1"	254 lb
82.14 - 126.9:1	350	250.00	17.5	18	300	803	120	100	5	100	60.02	18	64	164.5 kg
	13.8"	9.8"	0.7"	0.7"	11.8"	31.6"	4.7"	3.9"	0.2"	3.9"	2.36"	0.7"	2.5"	364 lb

Detailed drawings and CAD models available on request. Ratios above the basic range shown are available on request. Alternative gearbox types and arrangements i.e. right angle output, hollow shaft etc. also available.

Modified dimensions for shafts and flanges available on request.

RM210 VALVE OPTIONS

This range of bolt on valves offers very sensitive speed and directional control. One frictionless matched spool and sleeve assembly is offered with two alternative means of actuation.

CONFIGURATION

As standard these valves can be supplied with either EQUAL POWER or BIASED POWER spools, the latter is suitable for hoisting applications (normal power for lifting - reduced power for lowering).

The direction of reduced power must be stated when ordering CW or CCW, when viewed on the output shaft of the motor or geared motor.

1. Remotely Controlled (RCV) - This option is usually controlled from a remote position by one of the PC series or LC2 units. A variable air pilot signal is

applied to either end of the valve spool, depending on the required direction of motor rotation. The pilot pressure range is between 1.4 bar / 20 psi and 4.8 bar / 70 psi, increased pilot pressure give increased speed. The valve is spring centered to neutral.

2. Hand Controlled (HCV) - The control valve spool is operated directly by a lever mechanism. Speed increase is obtained as the lever is moved in either direction from the center (neutral) position.

Pressure Drop - Minimal pressure drop will be experienced through the valves, having the effect of maintaining the output torque while reducing the motor output speed by approximately 10-15% at 6 bar / 90 psi at maximum power. The starting torque remains unaffected.

REMOTE CONTROL VALVE - 3/4 BSP PORTS

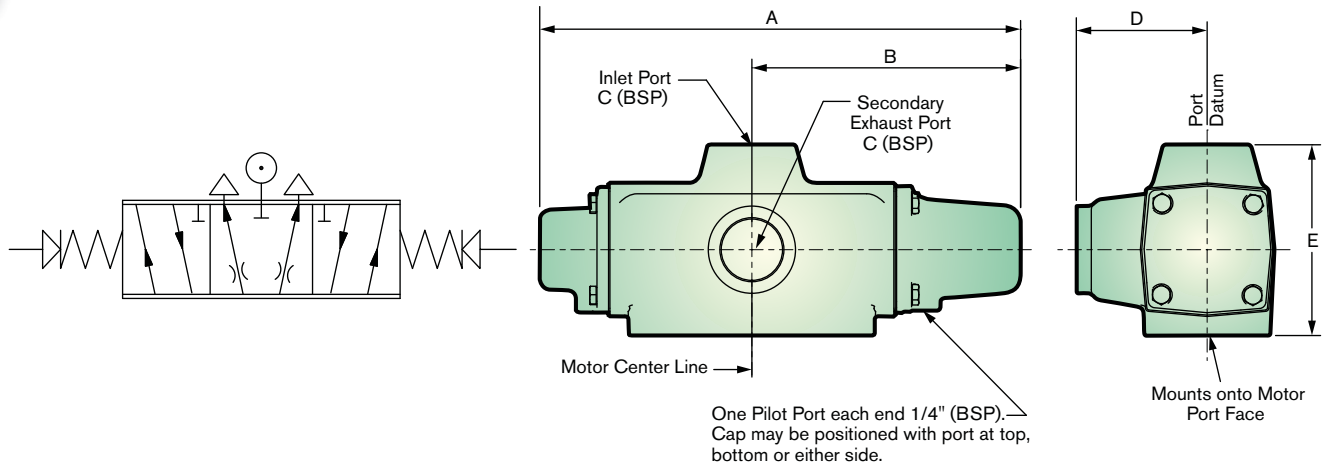

Modified threads and other valve options are available upon request. Please contact SPX Hydraulic Technologies.

A	B	C (BSP)	D	E	Approx. WT.
210.8	118.1	19.0	60.9	83.8	3.8 kg
8.3"	4.65"	3/4	2.4"	3.3"	8.5 lbs.

HAND CONTROL VALVE - 3/4 BSP PORTS

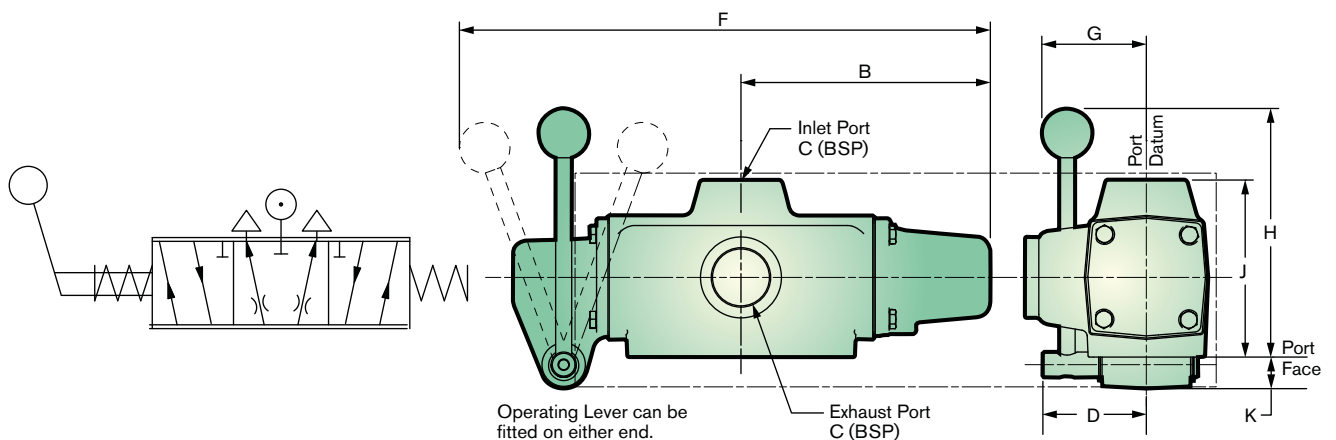

Modified threads and other valve options are available upon request. Please contact SPX Hydraulic Technologies.

B	C (BSP)	D	F	G	H	J	K	Approx. WT.
118.1	19.0	60.9	269.2	60.9	162.5	83.8	21.0	3.8 kg
4.65"	3/4	2.4"	10.6"	2.4"	6.4"	3.3"	0.83"	8.5 lbs.

RM210 VALVE OPTIONS SPARE PARTS LISTS

REMOTE CONTROL VALVE - 3/4 BSP PORTS

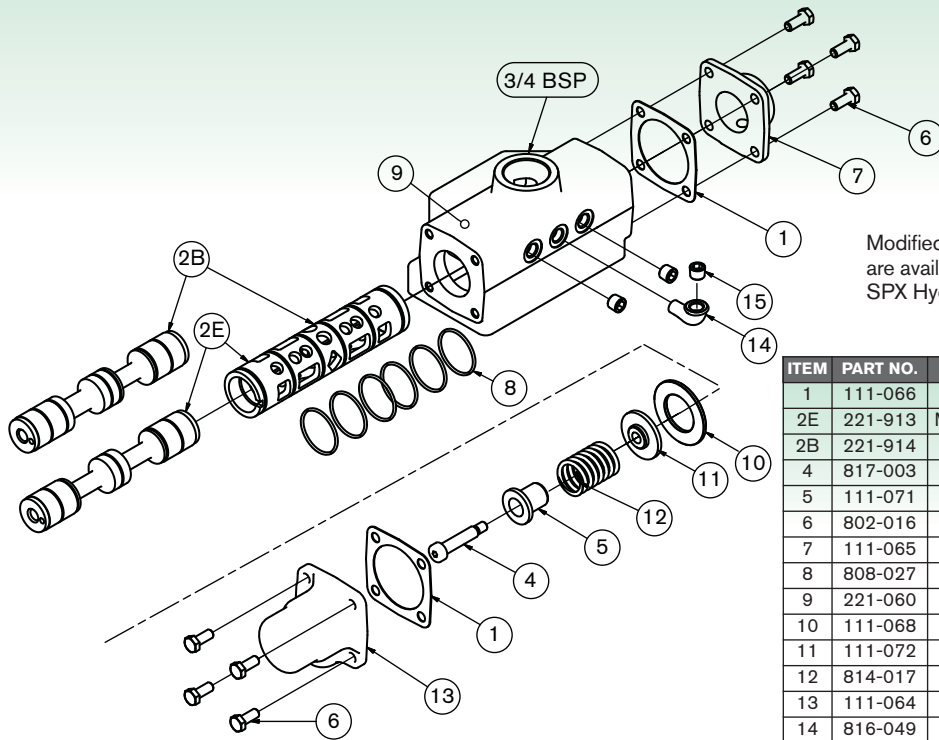

Modified threads and other valve options are available upon request. Please contact SPX Hydraulic Technologies.

ITEM	PART NO.	DESCRIPTION	QTY.
1	111-066	End Cap Gasket	2
2E	221-913	Matched Spool and Sleeve (Equipower)	1
2B	221-914	Matched Spool and Sleeve (Biased)	1
4	817-003	Shoulder Screw 8mm	1
5	111-071	Centering Shaft Guide	1
6	802-016	Hex Head Screw M6 x 16	8
7	111-065	End Cap - Plain End	1
8	808-027	O-Ring 27, 5 x 30	6
9	221-060	Valve Body	1
10	111-068	Valve Sleeve Spacer	1
11	111-072	Washer, Spring Centering	1
12	814-017	Spring D13040	1
13	111-064	End Cap - Spring End	1
14	816-049	Elbow M/F 1/8" BSPT	1
15	816-063	Plug 1/8" BSPT	3



HAND CONTROL VALVE - 3/4 BSP PORTS

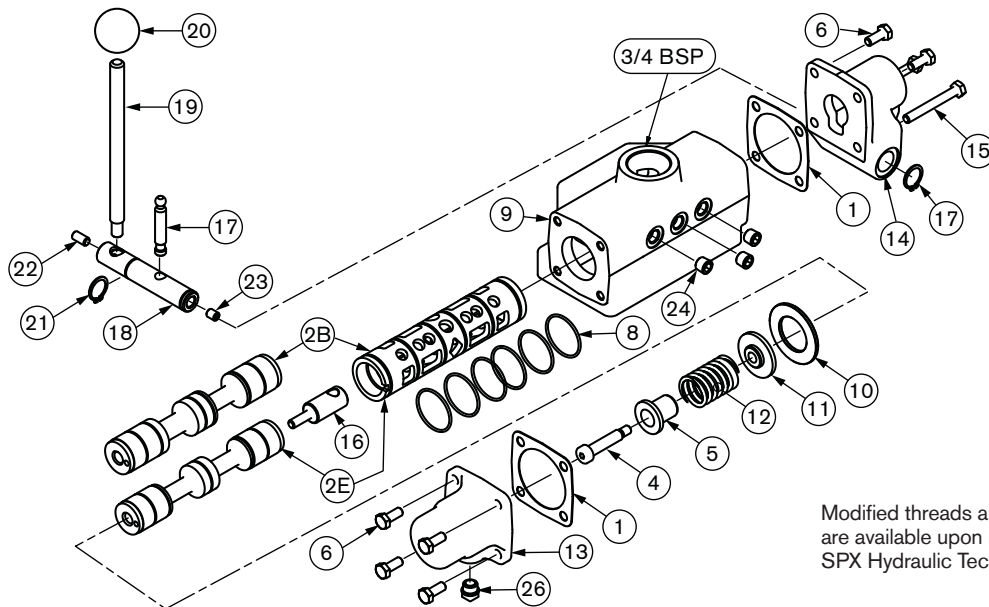

Modified threads and other valve options are available upon request. Please contact SPX Hydraulic Technologies.

ITEM	PART NO.	DESCRIPTION	QTY.
1	111-066	End Cap Gasket	2
2E	221-913	Matched Spool and Sleeve (Equipower)	1
2B	221-914	Matched Spool and Sleeve (Biased)	1
4	817-003	Shoulder Screw 8mm	1
5	111-071	Centering Shaft Guide	1
6	802-016	Hex Head Screw M6 x 16	6
8	808-027	O-Ring 27, 5 x 30	6
9	221-060	Valve Body	1
10	111-068	Valve Sleeve Spacer	1
11	111-072	Washer, Spring Centering	1
12	814-016	Spring 323714	1
13	111-064	End Cap - Spring End	1

ITEM	PART NO.	DESCRIPTION	QTY.
14	113-041	Hand Lever Cap	1
15	802-024	Hex Head Bolt M6 x 50	2
16	113-024	Toggle Shaft	1
17	113-026	Toggle Pin	1
18	113-008	Hand Lever Pivot	1
19	313-002	Hand Lever	1
20	818-002	Black Plastic Knob 31mm	1
21	804-013	Circlip 20mm External	2
22	515-010	Grub Screw M8 x 10	1
23	815-002	Grub Screw M8 x 16	1
24	816-063	Plug 1/8" BSPT	3
26	113-050	Vent Plug	1

RM210 PARKING BRAKE INSTALLATION DETAILS

The brake module bolts directly onto the motor mounting face and has exactly the same interface as the motor. As shown on the drawing below, the brake consists of two spring applied shoes pressed against a central hub. These shoes are released by applying air pressure to the cylinder/piston assembly. The brake torque can be varied by means of two spring adjusters

but it is normally set so that a pilot pressure of 4.1 bar / 60 psi will fully release it. Pressures below this level will progressively reduce the braking torque available. The brakes are set at the plant but it may be necessary to make adjustments on site to suit the individual application.

BRAKE VIEW

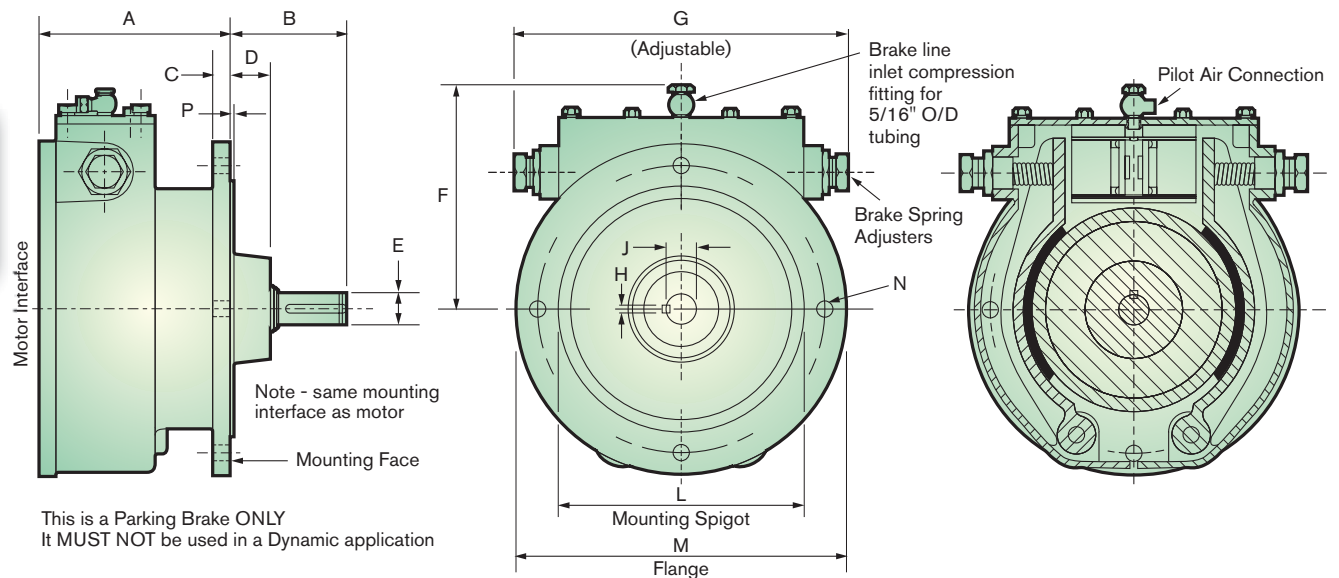

A	B	C	D	E	F	G	P	H	J	L	M	N-MOUNTING HOLES			
												NO.	Ø	P.C.D.	BOLT LENGTH (MAX)
114.3	93.9	10.9	45.7	18.9	129.5	236.2	4.0	5.9	21.1	179.9	254	101.6	13.9	215.9	725.8
4.5"	3.7"	0.43"	1.8"	0.7475"	5.1"	9.3"	0.16"	0.2355"	0.832"	7.0855"	10.0"	4"	0.55"	8.5"	28.575"

CIRCUITS

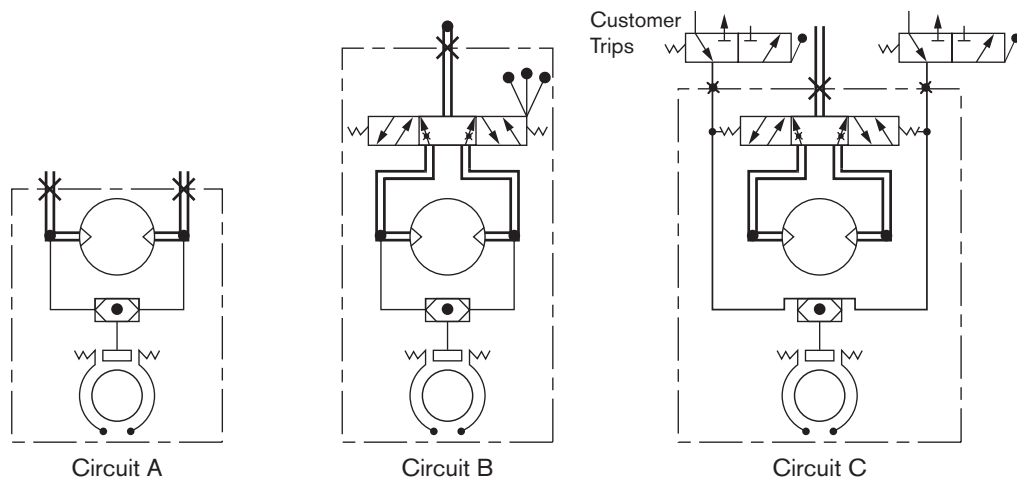

Circuit (A) - Applies to braked motors supplied without control valving. The unit will be fitted with a shuttle valve to allow brake operation for dual rotation.

Circuit (B) - Units supplied with hand (HCV) controlled reversible valves. If trips are required they must be of the mechanical style (customer's supply).

Circuit (C) - Units supplied with remotely controlled valves. When override trips are required, they must be superimposed in the signal line close to the motor unit and be of the 3 way style. (Signal lines cut and exhausted in the tripped position.)

RM210 PARKING BRAKE SPARE PARTS LIST & FOOT BRACKET

PARKING BRAKE SPARE PARTS LIST

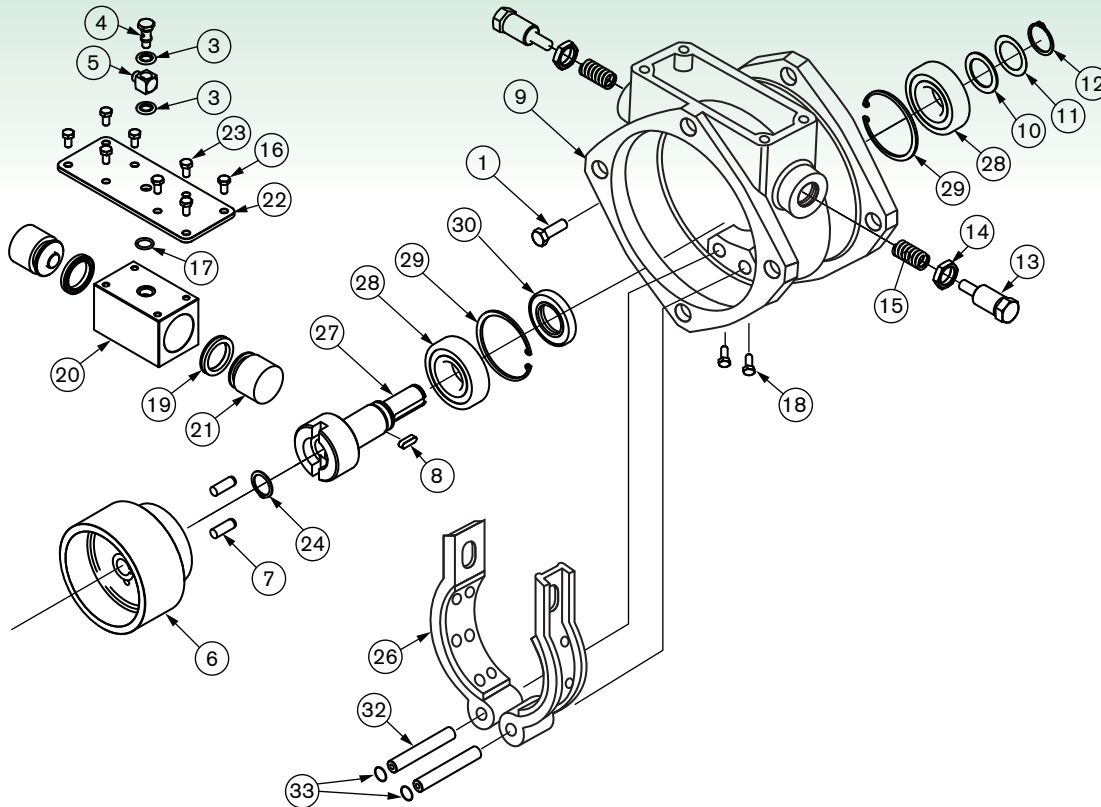

ITEM	PART NO.	DESCRIPTION	QTY.
1	802-072	Set Screw M15 x 25	4
3	808-090	Bonded Seal 1/4" BSP Dowty	2
4	816-004	Banjo Bolt Only 1/8" BXP	1
5	816-005	Banjo Body C/W Nut & Pin 5/16"	1
6	212-001	Brake Wheel	1
7	806-001	Dowel Dia 10 x 30 Lg	2
8	811-001	Key 6 Sq. x 30mm (K124)	1
9	222-008	Brake Housing	1
10	300-049	Shim - Output	5
11	300-035	Output Shaft Spacer	1
12	804-009	Circlip 27mm External	1
13	102-009	Brake Spring Adjuster	2
14	102-024	1/2" BSP Hex Nut	2
15	814-001	Spring 223712	2
16	802-016	Hex Head Screw M6 x 16	4

ITEM	PART NO.	DESCRIPTION	QTY.
17	212-030	Piston Block O-Ring	1
18	802-025	Hex Head Screw M6 x 25	2
19	808-075	U Packing U110	2
20	212-014	Piston Block	1
21	202-011	Brake Piston	2
22	212-013	Block Support Plate	1
23	802-012	Hex Head Screw M6 x 12	2
24	804-006	Circlip 19mm External	1
26	212-901	Brake Shoe Assembly	2
27	212-005	Output Shaft	1
28	807-008	Ball Bearing	2
29	804-058	Circlip 62mm Internal	2
30	808-044	Ollseal 30x62x10/R4	1
32	212-003	Brake Shoe Pivot	2
33	804-002	Circlip 11mm External	2

FOOT BRACKET

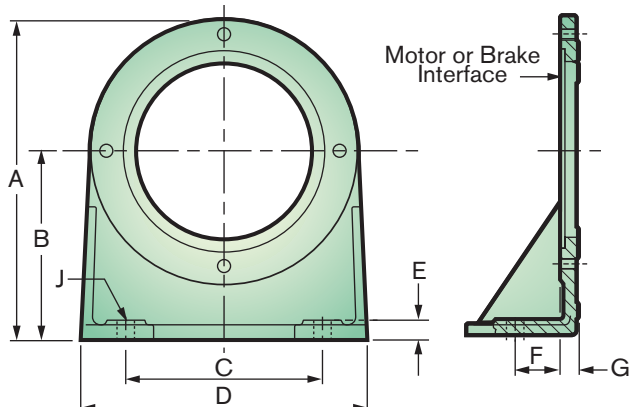

A	B	C	D	E	F	G	H	J
309.8	179.7	190.5	279.4	20.3	41.9	19.0	-	2 x Ø 18.0
12.2"	7.077"	7.50"	11.0"	0.8"	1.65"	0.75"	-	2 x Ø 0.71"

RM310 PEAK POWER 7.5kW (10HP) PERFORMANCE DATA

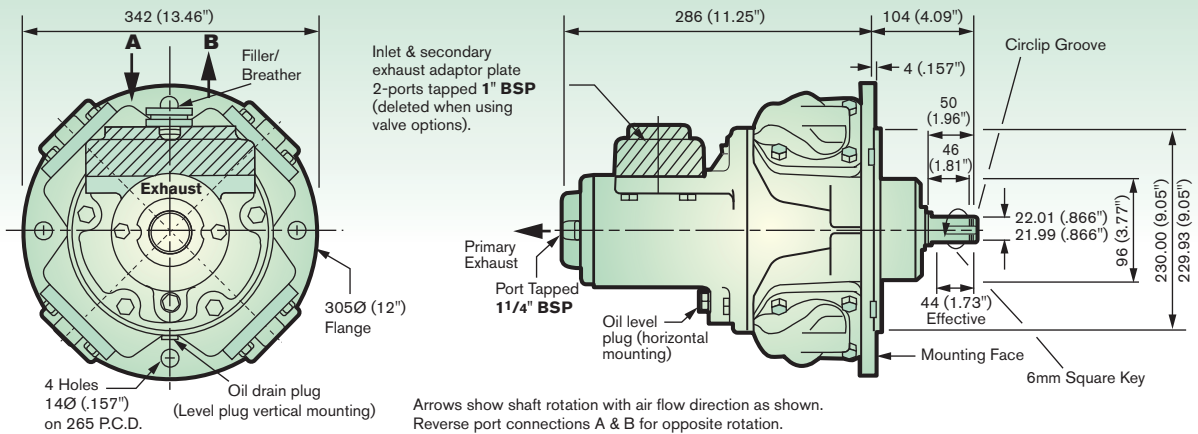

Reading Graphs - Scales have been adjusted to enable bar and psi to be read from a common curve. Therefore only read psi with the left hand axis and bar with the right hand axis.

GRAPH 1 TORQUE - SPEED

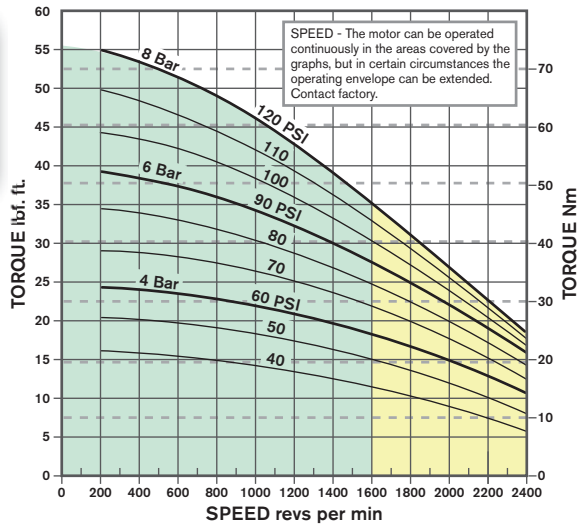

GRAPH 2 STARTING TORQUE - PRESSURE

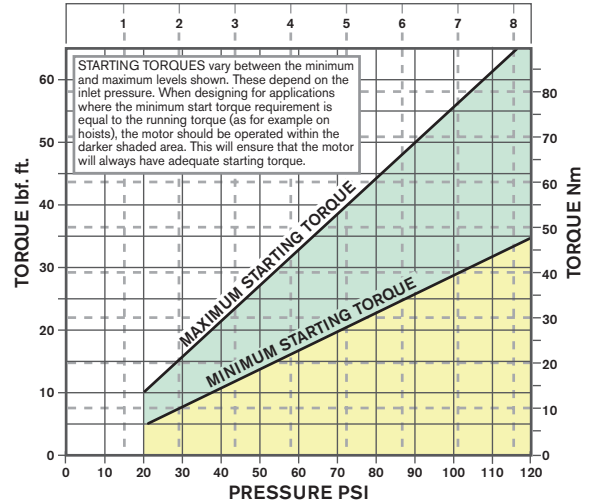

GRAPH 3 POWER - SPEED

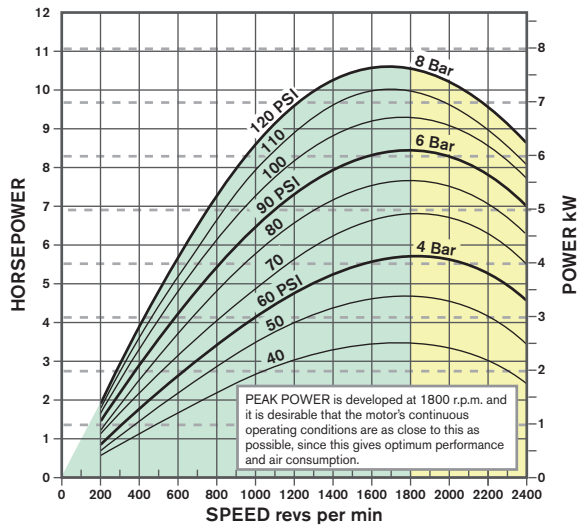

GRAPH 4 CONSUMPTION - SPEED

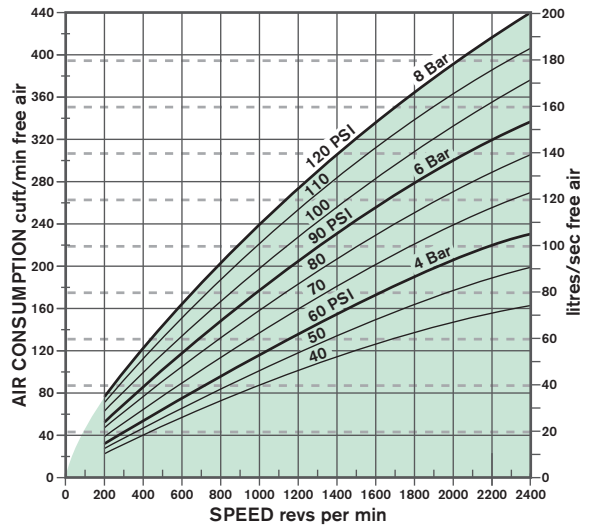

Lubricating Oil Capacities - Horizontal 350 ml / 12.5 fl. oz., Vertical 600 ml / 21 fl. oz. Use a good quality hydraulic oil with a viscosity of around 100cSt (460SSU) at 40° C / 104° F.

Airline Filtration and Lubrication - Use 64 micron filtration or better. Choose a lubricator suitable for the flow required. Prior to initial start-up, inject oil into the inlet port. Lubricator drop rate: 3-4 drops/minute continuous operation. Lubrication drop rate 6-10 drop/minute intermittent operation.

General Data -

- Mass** (motor only) 48 kgs / 106 lbs.
- Moment of Inertia** of rotating parts 1.8 gm² / 6 lb. in² (motor only)
- Max Overhung Force** on motor shaft 1330 N / 300 lbf.
- Temperature Range** -20° C to +80° C / -4° F to +176° F

RM310 MOTOR SPARE PARTS LIST

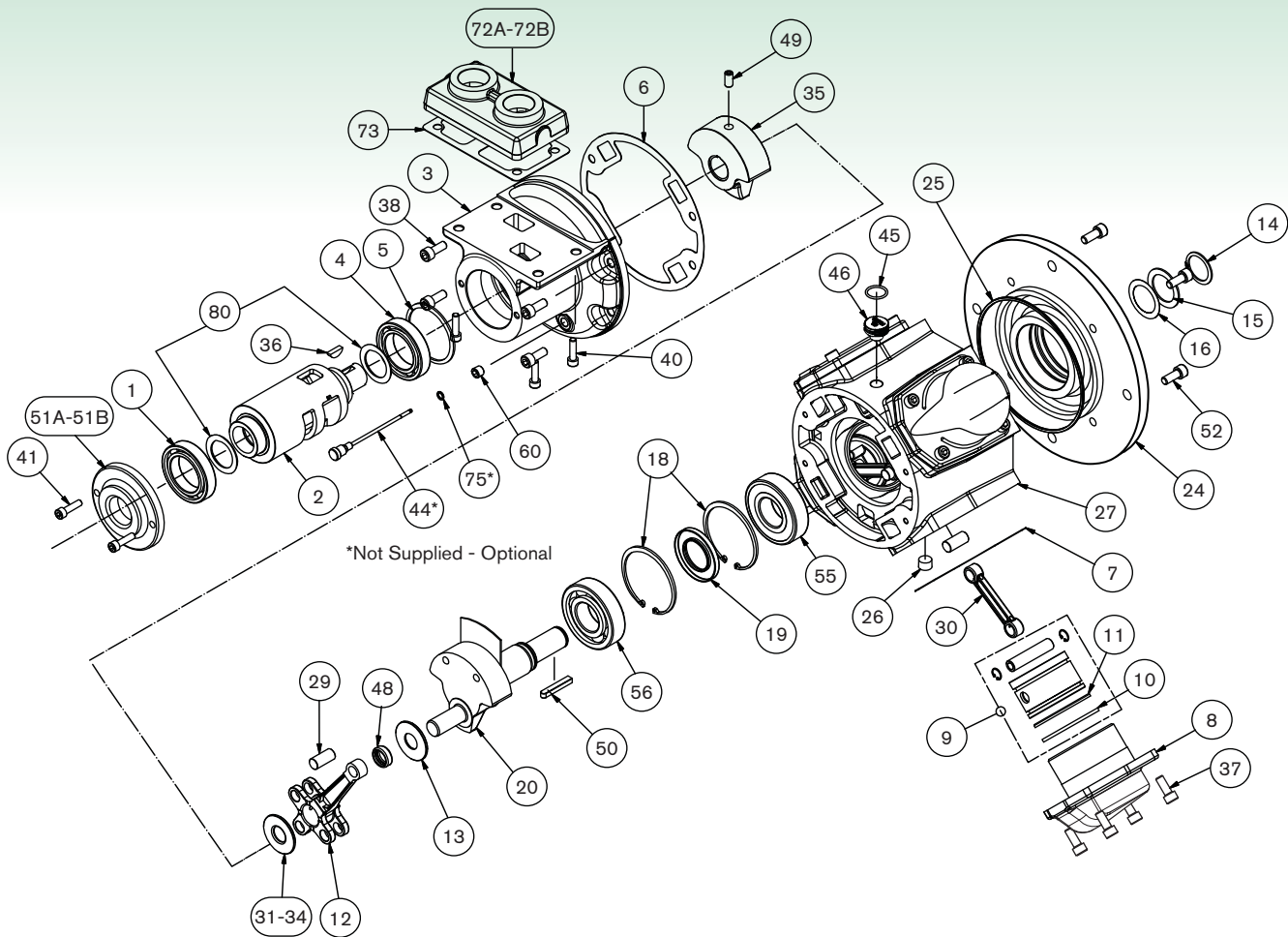

*Not Supplied - Optional

ITEM	PART NO.	DESCRIPTION	QTY.	KIT NO.
1	807-020	Rotary Valve Bearing (Outer)	1	
2	330-059	Rotary Valve	1	
3	330-011	Rotary Valve Housing	1	
4	807-001	Rotary Valve Bearing (Inner)	1	
5	804-054	Rotary Valve Bearing Circlip	1	
6	300-001	Rotary Valve Housing Gasket	1*	339-911
7	310-030	Cylinder Gasket	4*	339-911
8	310-082	Cylinder	4	
9	330-902A	Piston Assembly	4	
10	300-024	Compression Ring	4*	339-911
11	300-022	Oil Control Ring	4*	339-911
12	320-077	King Rod	1	
13	320-013	Crankshaft Spacer	2	
14	804-012	Crankshaft Circlip	1	
15	310-036	Crankshaft Spacer	1	
16	310-049	Crankshaft Spacer Shim	5	
18	804-062	Crankshaft Bearing Circlip	2	
19	808-045	Crankshaft Oilseal	1*	339-911
20	330-911	Std. Crankshaft Assembly	1	
24	330-076	Std. Flange Plate	1	
25	808-026	Flange Plate Seal	1*	339-911
26	816-071	Plug	1	
27	330-012	Engine Case	1	
29	320-081	Queen Rod Pivot	3	
30	330-078	Queen Rod	3	
31	320-052	Crank Spacer SELECT	1	
32	320-053	Crank Spacer ON	1	
33	320-054	Crank Spacer ASSEMBLY	1	

ITEM	PART NO.	DESCRIPTION	QTY.	KIT NO.
35	330-010	Balance Weight	1	
36	811-010	Woodruff Key	1	
37	802-053	Cylinder Bolts	16	
38	802-053	Valve Housing Bolts	4	
40	802-032	Adaptor Plate Bolt	4	
41	802-032	Exhaust Cover Bolts	2	
44	300-040	Dipstick (vertical mounting)	1	
45	808-004	Seal (transit only)	1	
46	130-066	Breather Plug	1	
48	807-065	Needle Bearing	1	
49	815-002	Grub Screw	1	
50	811-003	Key	1	
51A	330-005	Rotary Valve Exhaust Cover BSP	1	
51B	330-105	Rotary Valve Exhaust Cover NPT	1	
52	810-002	Flange BoltS	8	
55	807-009	Output Shaft Brg. (Outer)	1	
56	807-009	Output Shaft Brg. (Inner)	1	
60	816-063	Oil Level Plug	1	
72A	330-003	Inlet Adaptor Plate BSP	1	
72B	230-103	Inlet Adaptor Plate NPT	1	
73	330-004	Inlet Adaptor Plate Gasket	1*	339-911
75	808-008	Dipstick Seal	1*	339-911
	339-911	Seal Kit	1	
80	330-060	Rotary Valve Spacer	2	

Please note item 339-911 (Seal Kit) includes all items marked thus:*
Items marked thus select on assembly.

RM310 GEARED MOTOR INSTALLATION DETAILS

Maximum performance details listed below are at 6 bar / 90 psi. The performance under different conditions can be obtained by using the curves on page 22. A typical minimum gearbox efficiency of 90% can be expected. For higher pressures contact SPX Hydraulic Technologies.

The maximum overhung force is assumed acting midway along the output shaft; for other positions or higher loads on intermittent applications; contact SPX Hydraulic Technologies.

PERFORMANCE SUMMARY

GEARBOX RATIO	MAXIMUM POWER CONDITIONS					APPROX. MIN. START TORQUE		MAX. CONT. rmp	MAX. OVERHUNG FORCE		WEIGHT			
	kW	hp	rpm	TORQUE		Nm	lbf. ft		N	lbf.	GEARBOX	ADAPTER	GEARBOX KIT	MOTOR & GEARBOX
				Nm	lbf. ft									
5.15	6.37	8.5	350	165	122	170	125	461	2350	528	38	14	52	100
25.01	6.37	8.5	72	800	591	824	608	95	14060	3161	92	14	106	154
51.97	6.37	8.5	35	1663	1227	1713	1264	46	18830	4233	130	14	144	192
78.06	6.37	8.5	23	2498	1843	2573	1899	30	26070	5861	194	14	208	256
103.80	6.37	8.5	17	3322	2451	3421	2525	23	26070	5861	194	14	208	256
123.37	6.37	8.5	15	3948	2914	4066	3001	19	27600	6205	312	14	326	374
156.38	6.37	8.5	12	5004	3693	5154	3804	15	35280	7932	312	14	326	374
178.38	6.37	8.5	10	5708	4213	5879	4339	13	86311	19404	475	14	489	537
198.71	6.37	8.5	9	6359	4693	6549	4834	12	86311	19404	475	14	489	537
253.08	6.37	8.5	7	8099	5977	8342	6156	9	86311	19404	475	14	489	537

BASE MOUNTED GEAR BOX DIMENSIONS

For additional types and ratios contact SPX Hydraulic Technologies.

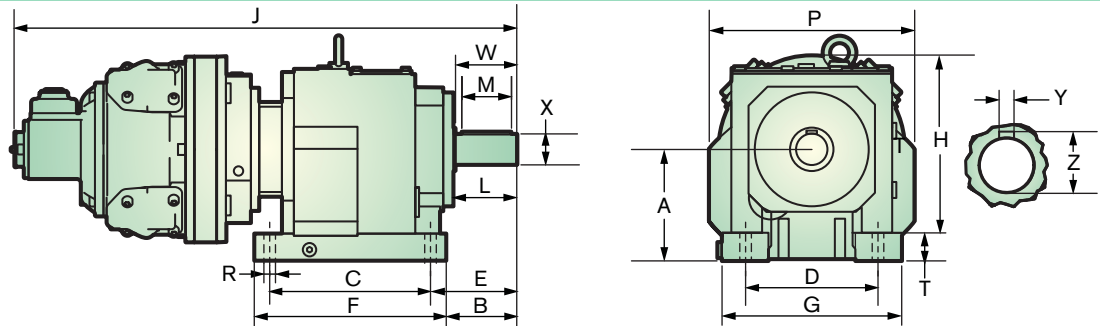

RANGE RATIO	A	B	C	D	E	F	G	H	J	L	M	P	R	T	W	X	Y	Z	MASS
4.28 - 6.9:1	115 + 35	92.5	165	135	110	200	195	265 + 35	722	83	70	300	13.5	25	70	40.01	12	43	96 kg
	4.5" + 1.4"	3.0"	6.5"	5.3"	4.3"	7.9"	7.7"	10.4" + 1.4"	28.4"	3.3"	2.8"	11.8"	0.5"	1.0"	2.8"	1.585"	0.5"	1.7"	212 lb
8.11 - 16.45	140 + 10	95	205	170	115	245	235	290 + 10	748	84	70	290	17.5	30	80	40.01	12	43	113 kg
	5.5" + 0.4"	3.7"	8.1"	6.7"	4.5"	9.6"	9.3"	11.4" + 0.4"	29.4"	3.3"	2.8"	11.4"	0.7"	1.2"	3.1"	1.585"	0.5"	1.7"	250 lb
20.81 - 31.32	180	115	260	215	140	310	290	364	806	104	80	332	17.5	45	100	50.01	14	53.5	150 kg
	7.1"	4.5"	10.2"	8.5"	5.5"	12.2"	11.4"	14.3"	31.7"	4.1"	3.1"	13.1"	0.7"	1.8"	3.9"	1.985"	0.6"	2.1"	330 lb
35.14 - 60.9:1	225	132	310	250	159.5	365	340	445	891	125	100	410	22	50	120	60.02	18	64	184 kg
	8.9"	5.2"	12.2"	9.8"	6.3"	14.4"	13.4"	17.5"	35.0"	4.9"	3.9"	16.1"	0.9"	2.0"	4.7"	2.38"	0.7"	2.5"	406 lb
78.06 - 88.46:1	250	150	370	290	185	440	400	507	965	145	110	462	26	55	140	70.02	20	74.5	252 kg
	9.8"	5.9"	14.6"	11.4"	7.3"	17.3"	15.7"	20.0"	38.0"	5.7"	4.3"	18.2"	1.0"	2.2"	5.5"	2.78"	0.8"	2.9"	556 lb

FLANGE MOUNTED GEAR BOX DIMENSIONS

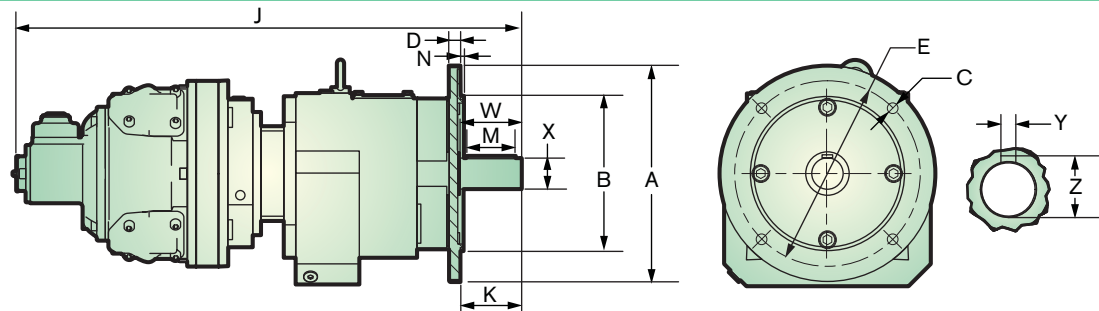

RANGE RATIO	A	B	C	D	E	J	K	M	N	W	X	Y	Z	MASS
4.28 - 6.9:1	300	230.00	13.5	15	265	721	80	70	4	80	40.01	12.0	43	96 kg
	11.8"	9.1"	0.5"	0.6"	10.4"	28.4"	3.1"	2.8"	0.2"	3.1"	1.6"	0.5"	1.7"	212 lb
8.11 - 16.45:1	300	230.00	13.5	16	265	749	80	70	4	80	40.01	12.0	43	113 kg
	11.8"	9.1"	0.5"	0.6"	10.4"	29.5"	3.1"	2.8"	0.2"	3.1"	1.6"	0.5"	1.7"	250 lb
20.81 - 31.32:1	350	250.01	17.5	18	300	806	100	80	5	100	50.01	14	53.5	150 kg
	13.8"	9.8"	0.7"	0.7"	11.8"	31.7"	3.9"	3.1"	0.2"	3.9"	2.0"	0.6"	2.1"	330 lb
35.14 - 60.9:1	450	350.00	17.5	20	400	891	120	100	5	120	60.02	18	64	188 kg
	17.7"	13.8"	0.7"	0.8"	15.7"	35.1"	4.7"	3.9"	0.2"	4.7"	2.4"	0.7"	2.5"	414 lb
78.06 - 88.46:1	550	450.00	17.5	22	500	969	140	110	5	140	70.02	20	74.5	252 kg
	21.7"	17.7"	0.7"	0.9"	19.7"	38.1"	5.5"	4.3"	0.2"	5.5"	2.8"	0.8"	2.9"	556 lb

Detailed drawings and CAD models available on request. Ratios above the basic range shown are available on request. Alternative gearbox types and arrangements i.e. right angle output, hollow shaft etc. also available.

Modified dimensions for shafts and flanges available on request.

RM310 VALVE OPTIONS

This range of bolt on valves offers very sensitive speed and directional control. One frictionless matched spool and sleeve assembly is offered with two alternative means of actuation.

CONFIGURATION

As standard these valves can be supplied with either EQUAL POWER or BIASED POWER spools, the latter is suitable for hoisting applications (normal power for lifting - reduced power for lowering).

The direction of reduced power must be stated when ordering CW or CCW, when viewed on the output shaft of the motor or geared motor.

1. Remotely Controlled (RCV) - This option is usually controlled from a remote position by one of the PC series or LC2 units. A variable air pilot signal is

applied to either end of the valve spool, depending on the required direction of motor rotation. The pilot pressure range is between 1.4 bar / 20 psi and 4.8 bar / 70 psi, increased pilot pressure give increased speed. The valve is spring centered to neutral.

2. Hand Controlled (HCV) - The control valve spool is operated directly by a lever mechanism. Speed increase is obtained as the lever is moved in either direction from the center (neutral) position.

Pressure Drop - Minimal pressure drop will be experienced through the valves, having the effect of maintaining the output torque while reducing the motor output speed by approximately 10-15% at 6 bar / 90 psi at maximum power. The starting torque remains unaffected.

REMOTE CONTROL VALVE - 1 BSP PORTS

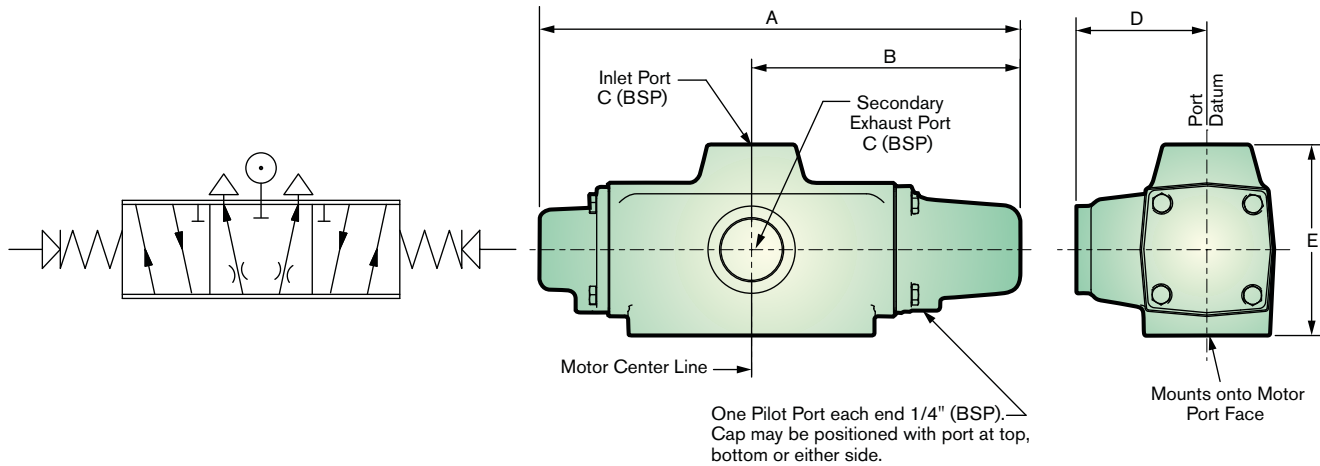

Modified threads and other valve options are available upon request. Please contact SPX Hydraulic Technologies.

A	B	C (BSP)	D	E	Approx. WT.
279.4	160.0	1	71.1	104.1	7.938 kg
11.0"	6.3"		2.8"	4.1"	17.5 lbs.

HAND CONTROL VALVE - 1 BSP PORTS

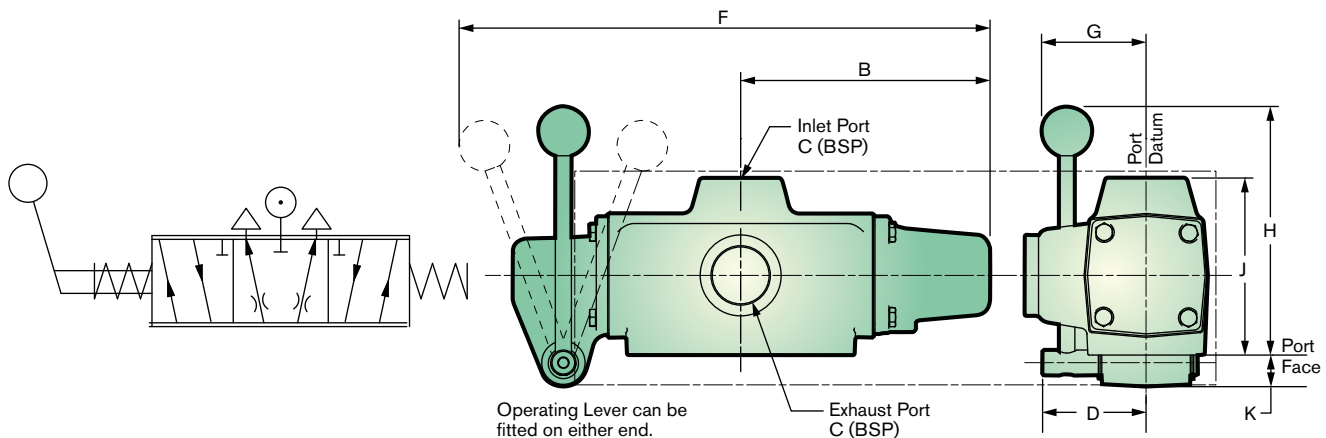

Modified threads and other valve options are available upon request. Please contact SPX Hydraulic Technologies.

B	C (BSP)	D	F	G	H	J	K	Approx. WT.
106.0	1	71.1	356.7	76.2	193.0	104.1	27.9	7.938 kg
6.3"		2.8"	14.4"	3.0"	7.6"	4.1"	1.1"	17.5 lbs.

RM310 VALVE OPTIONS SPARE PARTS LISTS

REMOTE CONTROL VALVE - 1 BSP PORTS

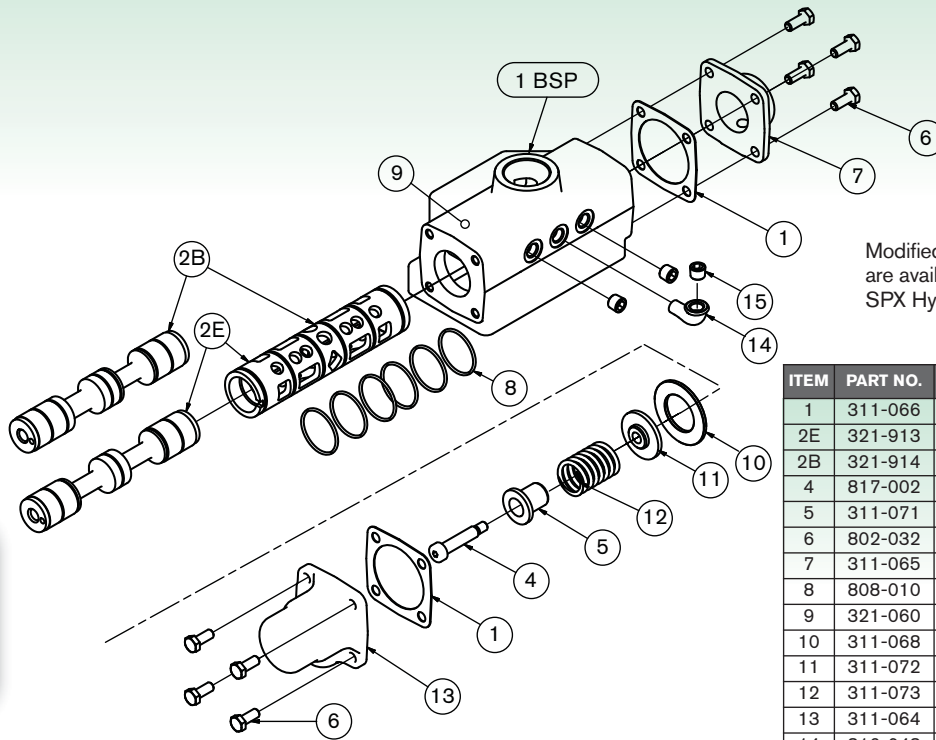

Modified threads and other valve options are available upon request. Please contact SPX Hydraulic Technologies.

ITEM	PART NO.	DESCRIPTION	QTY.
1	311-066	End Cap Gasket	2
2E	321-913	Matched Spool and Sleeve (Equipower)	1
2B	321-914	Matched Spool and Sleeve (Biased)	1
4	817-002	Shoulder Screw 10mm	1
5	311-071	Centering Shaft Guide	1
6	802-032	Set Screw M8 x 20	8
7	311-065	End Cap - Plain End	1
8	808-010	O-Ring 1-9/16" x 1-11/16"	6
9	321-060	Valve Body	1
10	311-068	Valve Sleeve Spacer	1
11	311-072	Washer, Spring Centering	1
12	311-073	Spring, Control Spool	1
13	311-064	End Cap - Spring End	1
14	816-048	Elbow M/F 1/4" BSPT	1
15	816-061	Plug 1/4" BSPT	3

HAND CONTROL VALVE - 1 BSP PORTS

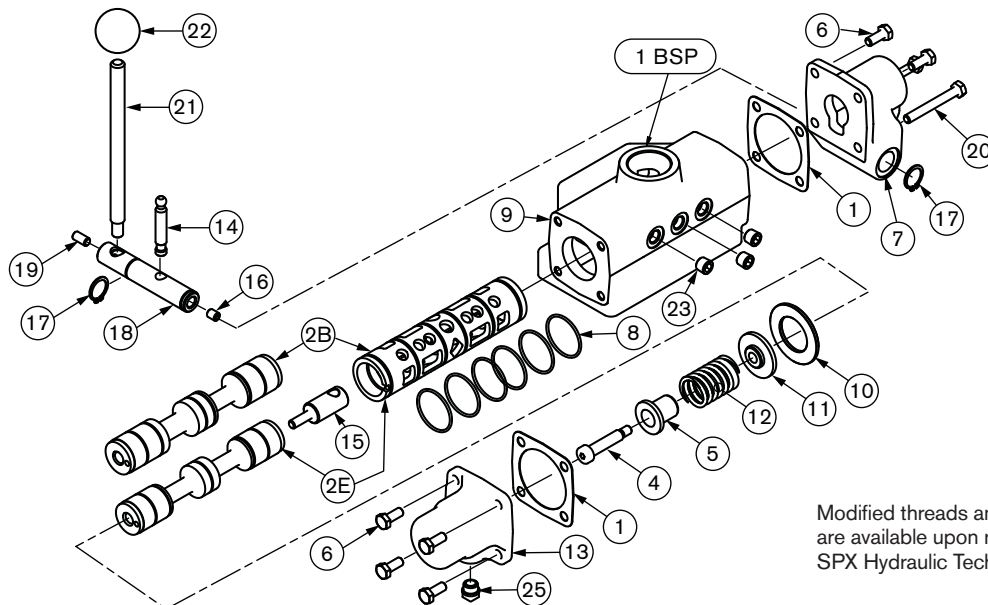

Modified threads and other valve options are available upon request. Please contact SPX Hydraulic Technologies.

ITEM	PART NO.	DESCRIPTION	QTY.
1	311-066	End Cap Gasket	2
2E	321-913	Matched Spool and Sleeve (Equipower)	1
2B	321-914	Matched Spool and Sleeve (Biased)	1
4	817-002	Shoulder Screw 10mm	1
5	311-071	Centering Shaft Guide	1
6	802-032	Hex Head Screw M8 x 20	6
7	313-041	Hand Lever Cap	1
8	808-010	O-Ring 1-9/16" x 1-11/16"	6
9	321-060	Valve Body	1
10	311-068	Valve Sleeve Spacer	1
11	311-072	Washer, Spring Centering	1
12	814-015	Spring 323720	1

ITEM	PART NO.	DESCRIPTION	QTY.
13	311-064	End Cap - Spring End	1
14	313-026	Toggle Pin	1
15	313-024	Toggle Shaft	1
16	815-010	Grub Screw M8 x 10	1
17	804-013	Circlip 20mm External	2
18	313-008	Hand Lever Pivot	1
19	815-002	Grub Screw M8 x 16	1
20	802-045	Hex Bolt M8 x 60	2
21	313-002	Hand Lever	1
22	818-002	Black Plastic Knob 1-1/2"	1
23	816-061	Plug 1/4" BSPT	3
25	113-050	Vent Plug	1

RM310 PARKING BRAKE INSTALLATION DETAILS

The brake module bolts directly onto the motor mounting face and has exactly the same interface as the motor. As shown on the drawing below, the brake consists of two spring applied shoes pressed against a central hub. These shoes are released by applying air pressure to the cylinder/piston assembly. The brake torque can be varied by means of two spring adjusters

but it is normally set so that a pilot pressure of 4.1 bar / 60 psi will fully release it. Pressures below this level will progressively reduce the braking torque available. The brakes are set at the plant but it may be necessary to make adjustments on site to suit the individual application.

BRAKE VIEW

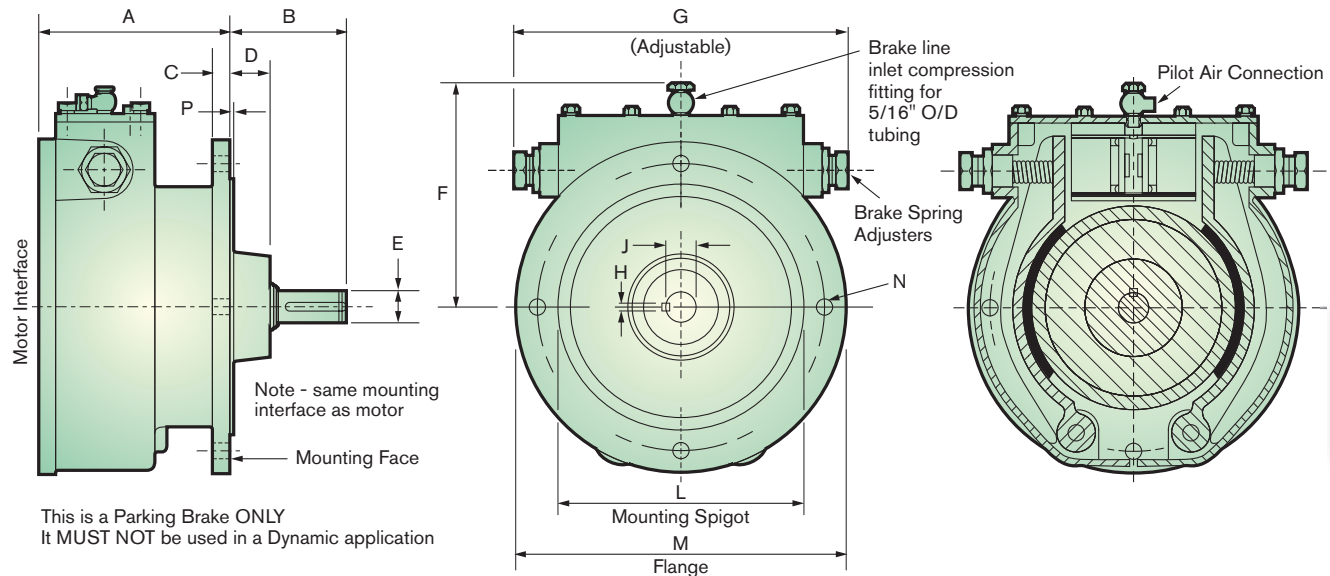

A	B	C	D	E	F	G	P	H	J	L	M	N-MOUNTING HOLES			
												NO.	Ø	P.C.D.	BOLT LENGTH (MAX)
139.7	104.1	13.9	45.7	22.0	160.0	269.2	4.0	5.9	24.5	229.9	304.8	101.6	13.9	264.1	887.0
5.5"	4.1"	0.55"	1.8"	0.8665"	6.3"	10.6"	0.16"	0.236"	0.965"	9.0535"	12.0"	4"	0.55"	10.4"	34.925"

CIRCUITS

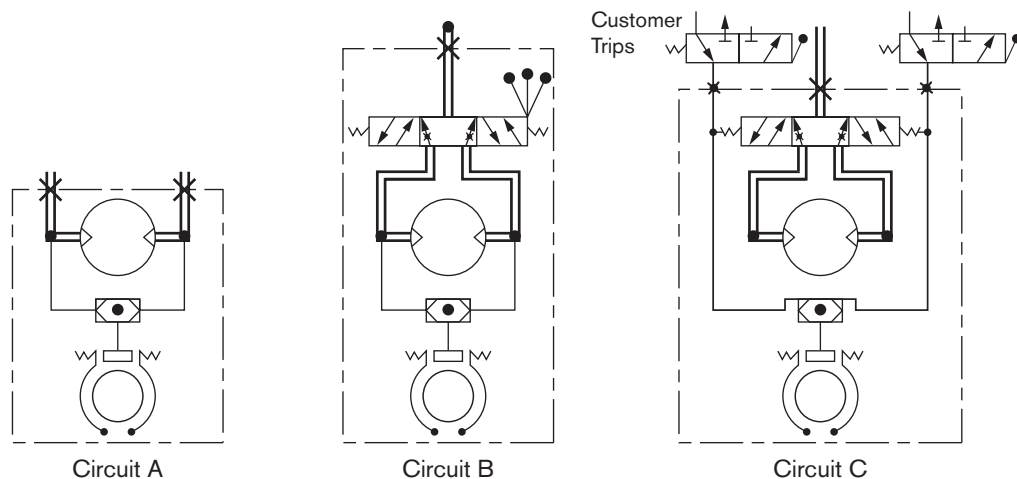

Circuit (A) - Applies to braked motors supplied without control valving. The unit will be fitted with a shuttle valve to allow brake operation for dual rotation.

Circuit (B) - Units supplied with hand (HCV) controlled reversible valves. If trips are required they must be of the mechanical style (customer's supply).

Circuit (C) - Units supplied with remotely controlled valves. When override trips are required, they must be superimposed in the signal line close to the motor unit and be of the 3 way style. (Signal lines cut and exhausted in the tripped position.)

RM310

PARKING BRAKE SPARE PARTS LIST & FOOT BRACKET

PARKING BRAKE SPARE PARTS LIST

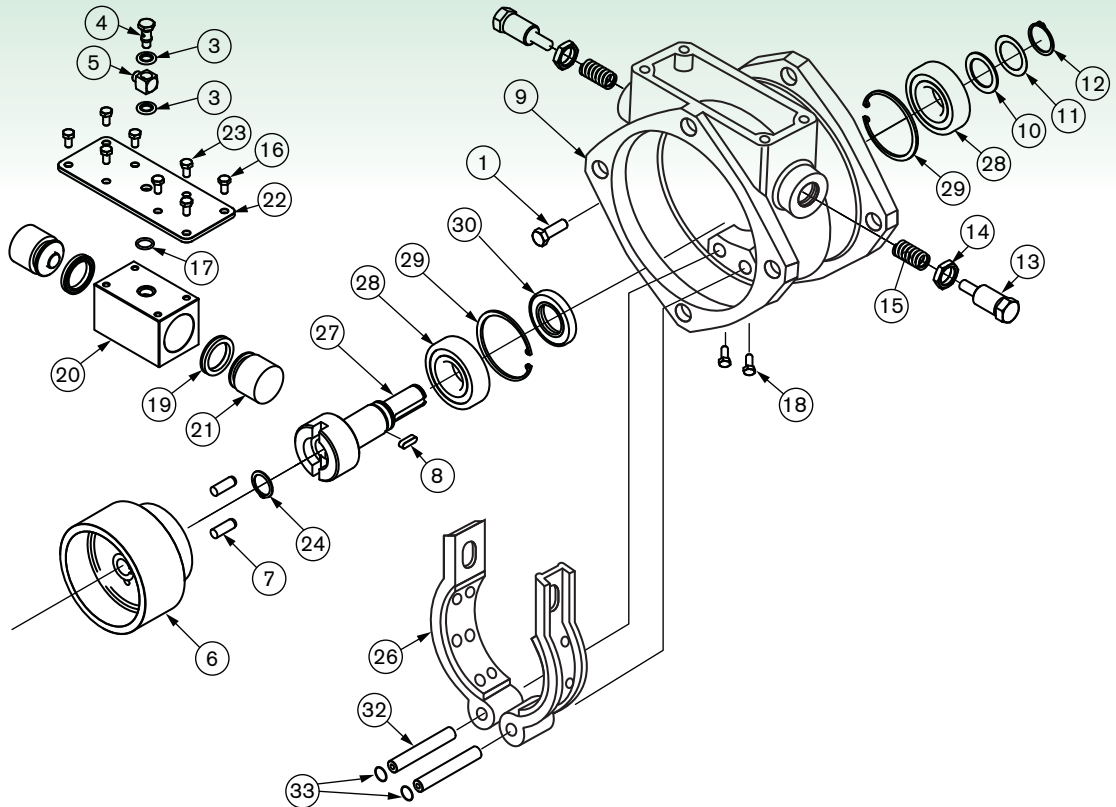

ITEM	PART NO.	DESCRIPTION	QTY.
1	802-073	Set Screw M12 x 30	4
3	808-090	Bonded Seal 1/4" BSP Dowty	2
4	816-004	Banjo Bolt Only 1/8" BXP	1
5	816-005	Banjo Body C/W Nut & Pin 5/16"	1
6	312-001	Brake Wheel	1
7	806-002	Dowel Dia 12 x 35 Lg	2
8	811-003	Key 6sq x 40mm	1
9	312-008	Brake Housing	1
10	320-049	Shim - Output	5
11	310-036	Output Shaft Spacer 3.55	1
11	310-037	Output Shaft Spacer 3.80	1
11	310-038	Output Shaft Spacer 4.05	1
12	804-012	Circlip 32mm External	1
13	102-009	Brake Spring Adjuster	2
14	102-024	1/2" BSP Hex Nut	2
15	814-008	Spring 243914	2

ITEM	PART NO.	DESCRIPTION	QTY.
16	802-031	Hex Head Screw M6 x 16	4
17	808-039	O-Ring 9/16" x 3/4"	1
18	802-020	Hex Head Screw M6 x 20	2
19	808-073	U Packing	2
20	312-014	Piston Block	1
21	302-011	Brake Piston	2
22	312-013	Block Support Plate	1
23	802-012	Hex Head Screw M8 x 12	2
24	804-007	Circlip 22mm External	1
26	312-901	Brake Shoe Assembly	2
27	312-005	Output Shaft	1
28	807-009	Ball Bearing	2
29	804-062	Circlip 72mm Internal	2
30	808-045	Oilseal 35 x 72 x 10/R4	1
32	312-003	Brake Shoe Pivot	2
33	804-122	Circlip 1/2" External	2

FOOT BRACKET

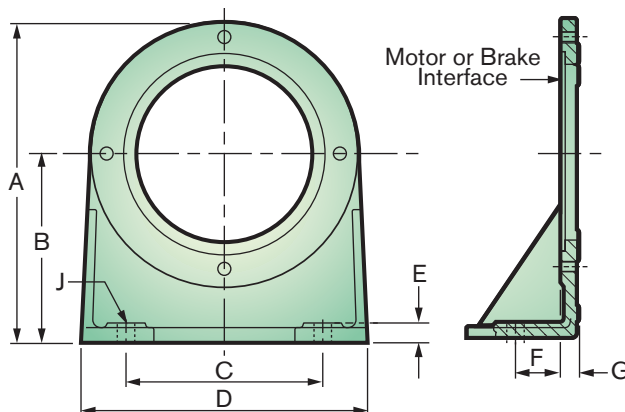

A	B	C	D	E	F	G	H	J
370.8	214.7	228.0	330.2	18.7	52.0	22.8	-	2 x Ø 21.0
14.6"	8.455"	8.98"	13.0"	0.74"	2.05"	0.9"	-	2 x Ø 0.83

RM410

PEAK POWER 14kW (19HP) PERFORMANCE DATA

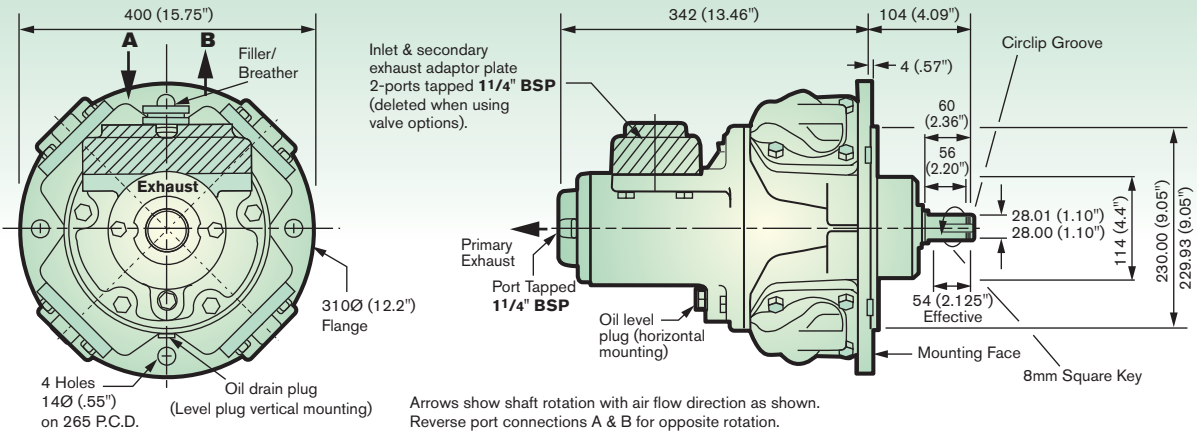

Reading Graphs - Scales have been adjusted to enable bar and psi to be read from a common curve. Therefore only read psi with the left hand axis and bar with the right hand axis.

GRAPH 1 TORQUE - SPEED

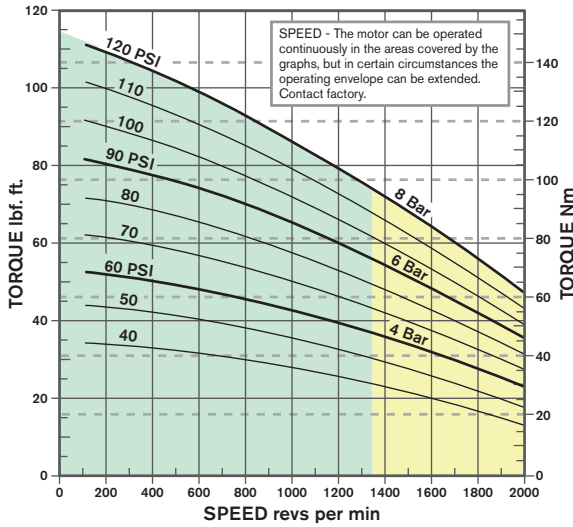

GRAPH 2 STARTING TORQUE - PRESSURE

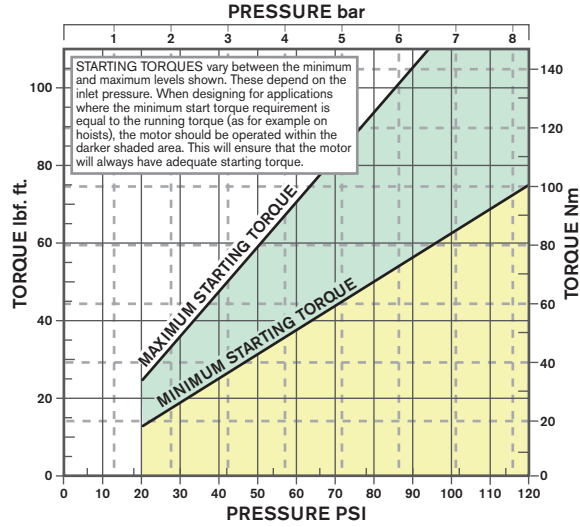

GRAPH 3 POWER - SPEED

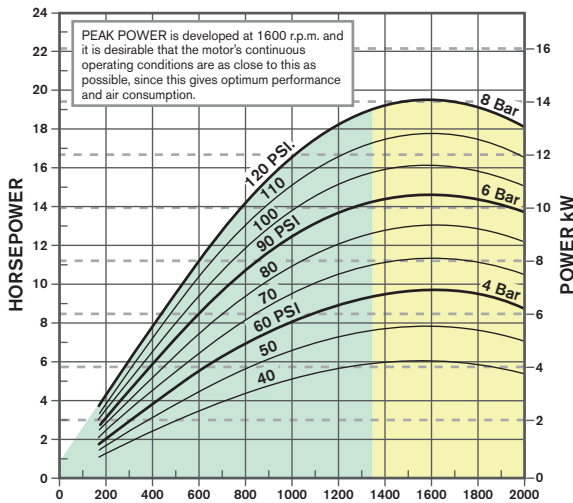

GRAPH 4 CONSUMPTION - SPEED

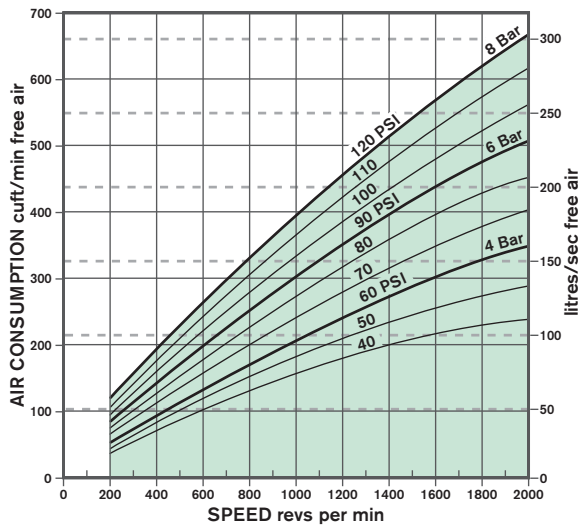

Lubricating Oil Capacities - Horizontal 500 ml / 18 fl. oz., Vertical 940 ml / 33 fl. oz. Use a good quality hydraulic oil with a viscosity of around 100cSt (460SSU) at 40°C / 104°F.

Airline Filtration and Lubrication - Use 64 micron filtration or better. Choose a lubricator suitable for the flow required. Prior to initial start-up, inject oil into the inlet port. Lubricator drop rate: 3-4 drops/minute continuous operation. Lubricator drop rate 6-10 drop/minute intermittent operation.

General Data -

Mass (motor only) 62 kgs / 137 lbs.

Moment of Inertia of rotating parts 4.1 gm² / 14 lb. in² (motor only)

Max Overhung Force on motor shaft 1330 N / 300 lbf.

Temperature Range -20°C to +80°C / -4°F to +176°F



RM410 MOTOR SPARE PARTS LIST

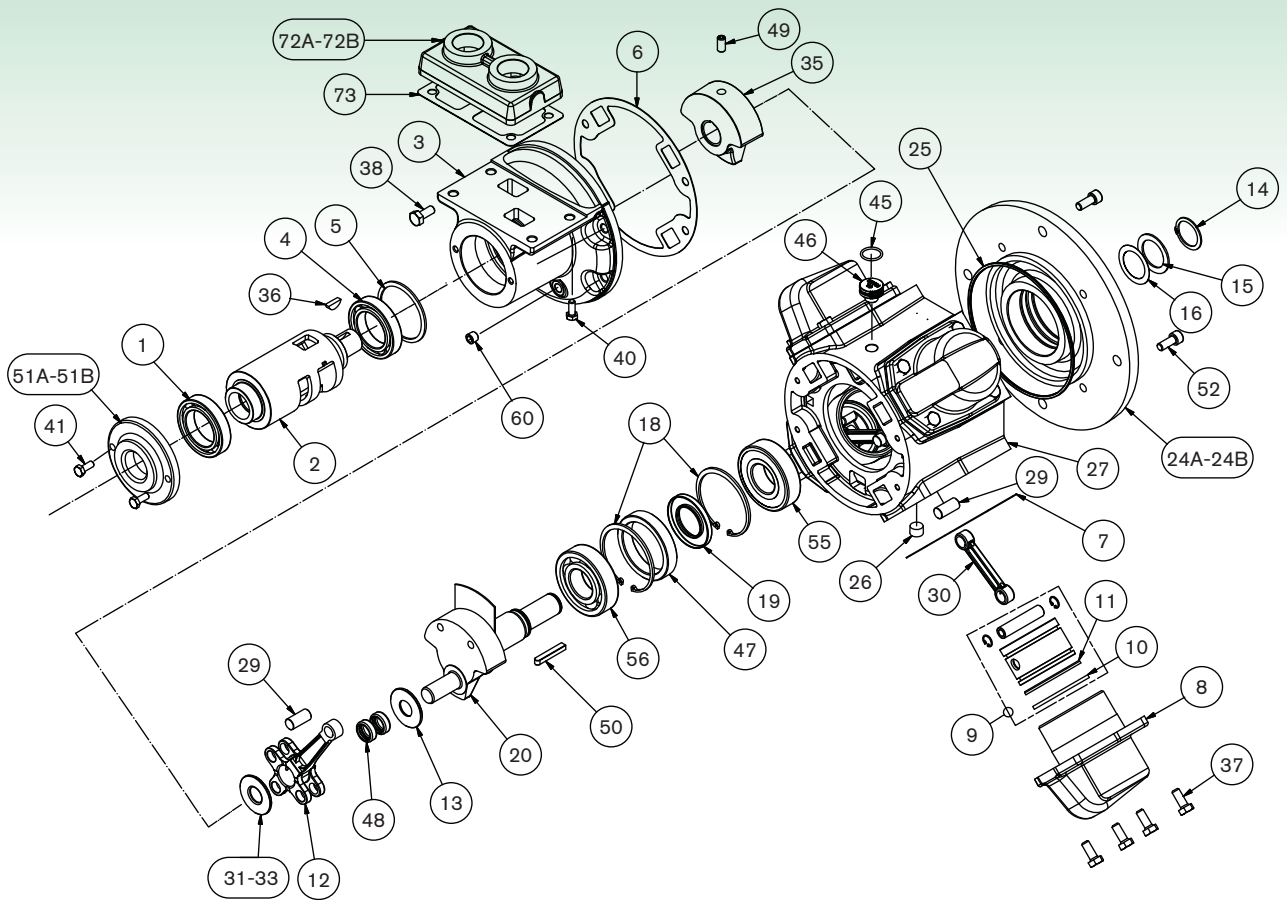

ITEM	PART NO.	DESCRIPTION	QTY.	KIT NO.
1	807-006	Rotary Valve Bearing (Outer)	1	
2	430-006	Rotary Valve	1	
3	430-011	Rotary Valve Housing	1	
4	807-005	Rotary Valve Bearing (Inner)	1	
5	804-066	Rotary Valve Bearing Circlip	1	
6	430-001	Rotary Valve Housing Gasket	1*	439-910
7	430-030	Cylinder Gasket	4*	439-910
8	430-082	Cylinder	4	
9	430-902A	Piston Assembly	4	
10	430-024	Compression Ring	4*	439-910
11	430-022	Oil Control Ring	4*	439-910
12	430-077	King Rod	1	
13	430-053	Crankshaft Spacer	2	
14	804-016	Crankshaft Circlip	1	
15	430-035	Crankshaft Spacer	1	
16	430-049	Crankshaft Spacer Shim	5	
18	804-068	Crankshaft Bearing Circlip	2	
19	808-048	Crankshaft Oilseal	1*	439-910
20	430-901	Std. Crankshaft Assembly	1	
24A	430-076	Std. Flange Plate	1	
24B	430-097	SAE Flange Plate	1	
25	808-018	Flange Plate Seal	1*	439-910
26	816-071	Plug	1	
27	430-012	Engine Case	1	
29	430-081	Queen Rod Pivot	3	
30	430-078	Queen Rod	3	
31	430-052	Crank Spacer SELECT	1	
32	430-053	Crank Spacer ON	1	
33	430-054	Crank Spacer ASSEMBLY	1	

ITEM	PART NO.	DESCRIPTION	QTY.	KIT NO.
35	430-010	Balance Weight	1	
36	811-009	Woodruff Key	1	
37	802-054	Cylinder Bolts	16	
38	802-054	Valve Housing Bolts	4	
40	802-054	Adaptor Plate Bolt	4	
41	802-033	Exhaust Cover Bolts	2	
45	808-004	Seal (transit only)	1	
46	130-066	Breather Plug	1	
47	430-083	Oil Seal Carrier	1	
48	807-045	Needle Bearing	2	
49	815-003	Grub Screw	1	
50	811-005	Key	1	
51A	430-005	Rotary Valve Exhaust Cover BSP	1	
51B	430-105	Rotary Valve Exhaust Cover NPT	1	
52	809-001	Flange Bolts	8	
55	807-013	Output Shaft Brg. (Outer)	1	
56	807-012	Output Shaft Brg. (Inner)	1	
60	816-074	Oil Level Plug	1	
72A	430-003	Inlet Adaptor Plate BSP	1	
72B	430-103	Inlet Adaptor Plate NPT	1	
73	430-004	Inlet Adaptor Plate Gasket	1*	439-910
	439-910	Seal Kit	1	

Please note item 439-910 (Seal Kit) includes all items marked thus:*
Items marked thus select on assembly.

RM410 GEARED MOTOR INSTALLATION DETAILS

Maximum performance details listed below are at 6 bar / 90 psi. The performance under different conditions can be obtained by using the curves on page 29. A typical minimum gearbox efficiency of 90% can be expected. For higher pressures contact SPX Hydraulic Technologies.

The maximum overhung force is assumed acting midway along the output shaft; for other positions or higher loads on intermittent applications; contact SPX Hydraulic Technologies.

PERFORMANCE SUMMARY

GEARBOX RATIO	MAXIMUM POWER CONDITIONS						APPROX. MIN. START TORQUE		MAX. CONT. rmp	MAX. OVERHUNG FORCE		WEIGHT			
	kW	hp	rpm	TORQUE		Nm	lbf. ft	N		lbf.	GEARBOX	ADAPTER	GEARBOX KIT	MOTOR & GEARBOX	
				Nm	lbf. ft										
5.06	11.25	15	316	288	213	317	234	390	3010	677	67	14	81	143	
24.94	11.25	15	64	1422	1049	1564	1154	79	13780	3098	132	14	146	208	
48.44	11.25	15	33	2761	2038	3037	2241	41	22270	5007	215	14	229	291	
69.36	11.25	15	23	3954	2918	4349	3209	28	31140	7001	312	14	326	388	
92.91	11.25	15	17	5296	3908	5825	4299	21	31140	7001	312	14	326	388	
123.59	11.25	15	13	7045	5199	7749	5719	16	86311	19404	475	14	489	551	
141.28	11.25	15	11	8053	5943	8858	6537	14	86311	19404	475	14	489	551	
177.23	11.25	15	9	10102	7455	11112	8201	11	101570	22835	635	14	649	711	
206.34	11.25	15	8	11761	8680	12938	9548	10	120000	26978	635	14	649	711	

For additional types and ratios contact SPX Hydraulic Technologies.

BASE MOUNTED GEAR BOX DIMENSIONS

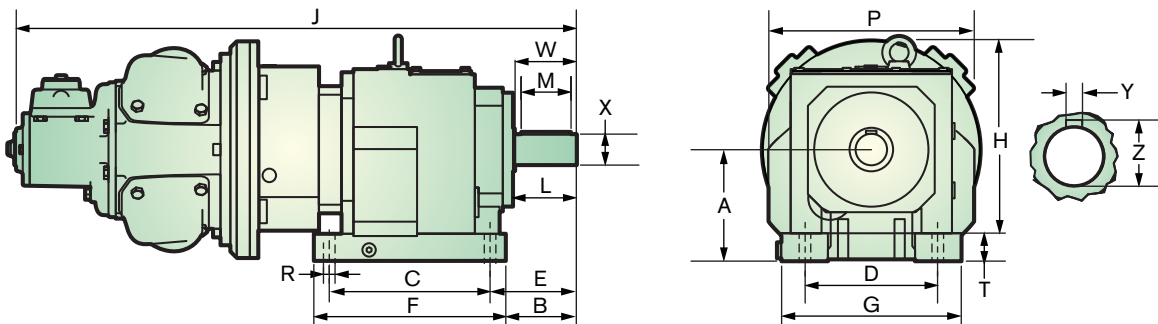

RANGE RATIO	A	B	C	D	E	F	G	H	J	L	M	P	R	T	W	X	Y	Z	MASS
3.49 - 6.72:1	140 - 35	115.00	205	170	135	245	235	315 + 35	865	104	80	350	17.5	30	100	50.01	14	53.5	143 kg
	5.5 - 1.3	4.5"	8.1"	6.7"	5.3"	9.7"	9.25"	12.4"+1.4"	34.1"	4.1"	3.2"	13.8"	0.7"	1.2"	3.9"	1.97"	0.6"	2.1"	315 lb
7.59 - 17.27:1	180	115.00	260	215	140	310	290	364	900	104	80	350	17.5	45	100	50.01	14	53.5	161 kg
	7.1"	4.5"	10.2"	8.5"	5.5"	12.2"	11.4"	14.3"	35.4"	4.1"	3.2"	13.8"	0.7"	1.8"	3.9"	1.97"	0.6"	2.1"	355 lb
19.48 - 35.14:1	225	132.00	310	250	159.5	365	340	445	959	125	100	410	22	50	120	60.02	18	64	208 kg
	8.9"	5.2"	12.2"	9.8"	6.3"	14.4"	13.4"	17.5"	37.8	4.9"	3.9"	16.1"	0.9"	1.97"	4.7"	2.4"	0.7"	2.5"	459 lb
37.57 - 57.56:1	250	150.00	370	290	185	440	400	507	1063	146	110	462	26	55	140	70.02	20	75	291 kg
	9.8"	5.9"	14.6"	11.4"	7.3"	17.3"	15.7"	19.96"	41.9"	5.8"	4.3"	18.2"	1.02"	2.2"	5.5"	2.8"	0.8"	2.9"	642 lb
62.12 - 81.04:1	315	220.00	410	340	260	490	450	578	1163	210	180	510	33	60	210	100.02	28	106	388 kg
	12.4"	8.7"	16.1"	13.4"	10.2"	19.3"	17.7"	22.755"	45.8"	8.3"	7.1"	20.1"	1.3"	2.4"	8.3"	3.9"	1.1"	4.2"	815 lb

FLANGE MOUNTED GEAR BOX DIMENSIONS

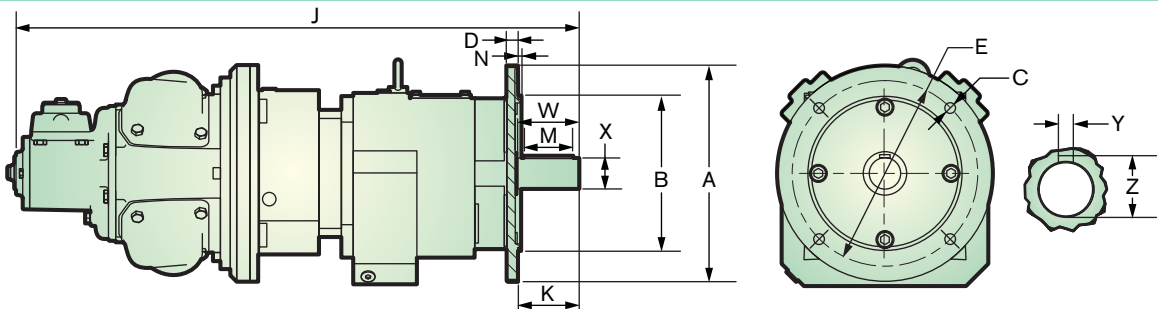

RANGE RATIO	A	B	C	D	E	J	K	M	N	W	X	Y	Z	MASS
3.49 - 6.72:1	350	250.01	17.5	16	300	865	100	80	4	100	50.01	14	53.5	143 kg
	13.8"	9.8"	0.7"	0.6"	11.8"	34.1"	3.9"	3.2"	0.2"	3.9"	1.96"	0.6"	2.1"	315 lb
7.59 - 17.27:1	350	250.01	17.5	18	300	906	100	80	5	100	50.01	14	53.5	161 kg
	13.8"	9.8"	0.7"	0.7"	11.8"	35.7"	3.9"	3.2"	0.2"	3.9"	1.96"	0.6"	2.1"	355 lb
19.48 - 35.14:1	450	350.00	17.5	20	400	959	120	100	5	120	60.02	18	64	208 kg
	17.7"	13.8"	0.7"	0.8"	15.7"	37.8"	4.7"	3.9"	0.2"	4.7"	2.4"	0.7"	2.5"	459 lb
37.57 - 57.56:1	450	350.00	17.5	22	400	1063	140	110	5	140	70.03	20	74.5	291 kg
	17.7"	13.8"	0.7"	0.9"	15.7"	41.9"	5.5"	4.3"	0.2"	5.5"	2.8"	0.8"	2.9"	642 lb
62.12 - 81.04:1	550	450	17.5	25	500	1125	170	140	5	210	90.02	25	106	388 kg
	21.7"	17.7"	0.7"	1.0"	19.7"	44.3"	6.7"	5.5"	0.2"	8.3"	3.54"	1.0"	4.2"	815 lb

Detailed drawings and CAD models available on request. Ratios above the basic range shown are available on request. Alternative gearbox types and arrangements i.e. right angle output, hollow shaft etc. also available.

Modified dimensions for shafts and flanges available on request.

RM410 VALVE OPTIONS

This range of bolt on valves offers very sensitive speed and directional control. One frictionless matched spool and sleeve assembly is offered with two alternative means of actuation.

CONFIGURATION

As standard these valves can be supplied with either EQUAL POWER or BIASED POWER spools, the latter is suitable for hoisting applications (normal power for lifting - reduced power for lowering).

The direction of reduced power must be stated when ordering CW or CCW, when viewed on the output shaft of the motor or geared motor.

1. Remotely Controlled (RCV) - This option is usually controlled from a remote position by one of the PC series or LC2 units. A variable air pilot signal is

applied to either end of the valve spool, depending on the required direction of motor rotation. The pilot pressure range is between 1.4 bar / 20 psi and 4.8 bar / 70 psi, increased pilot pressure give increased speed. The valve is spring centered to neutral.

2. Hand Controlled (HCV) - The control valve spool is operated directly by a lever mechanism. Speed increase is obtained as the lever is moved in either direction from the center (neutral) position.

Pressure Drop - Minimal pressure drop will be experienced through the valves, having the effect of maintaining the output torque while reducing the motor output speed by approximately 10-15% at 6 bar / 90 psi at maximum power. The starting torque remains unaffected.

REMOTE CONTROL VALVE - 1-1/4 BSP PORT

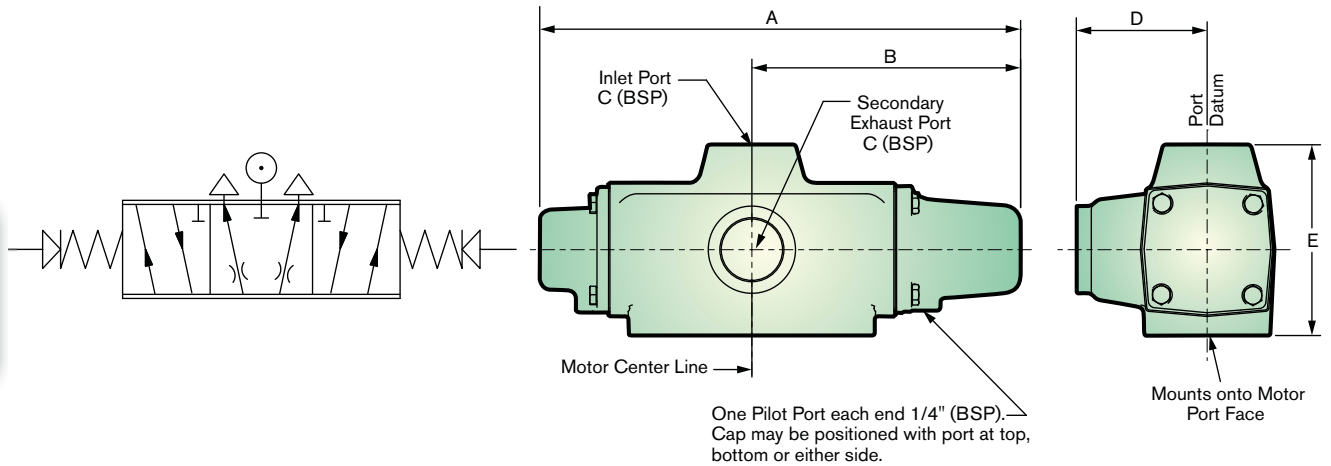

Modified threads and other valve options are available upon request. Please contact SPX Hydraulic Technologies.

A	B	C (BSP)	D	E	Approx. WT.
279.4	160.0	1-1/4	71.1	114.3	8.2 kg
11.0"	6.3"		2.8"	4.5"	18.13 lbs.

HAND CONTROL VALVE - 1-1/4 BSP PORT

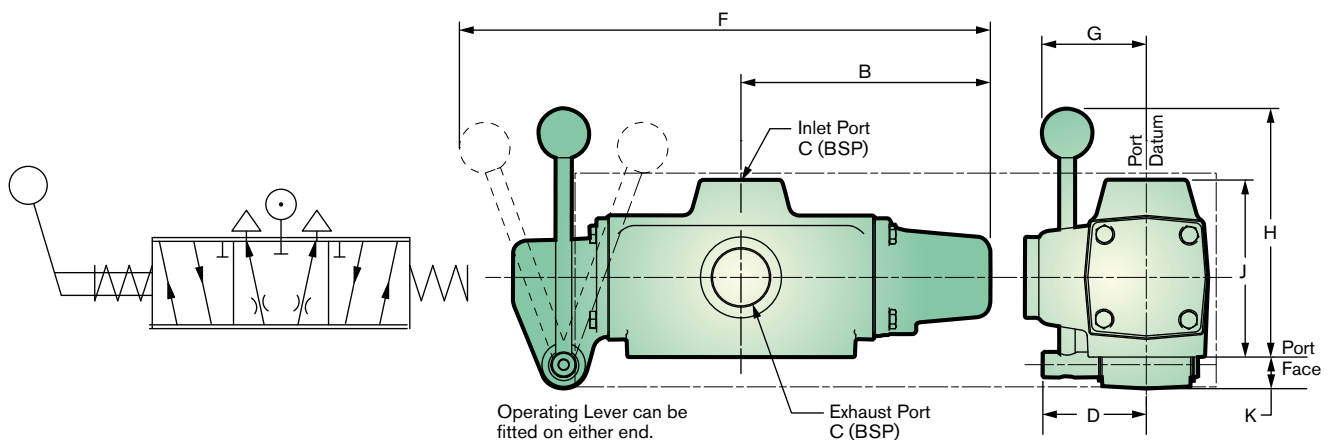

Modified threads and other valve options are available upon request. Please contact SPX Hydraulic Technologies.

B	C (BSP)	D	F	G	H	J	K	Approx. WT.
160.0	1-1/4	71.1	365.7	76.2	198.1	111.7	22.6	8.2 kg
6.3"		2.8"	14.4"	3.0"	7.8"	4.4"	0.89"	18.13 lbs.

RM410 VALVE OPTIONS SPARE PARTS LISTS

REMOTE CONTROL VALVE - 1-1/4 BSP PORT

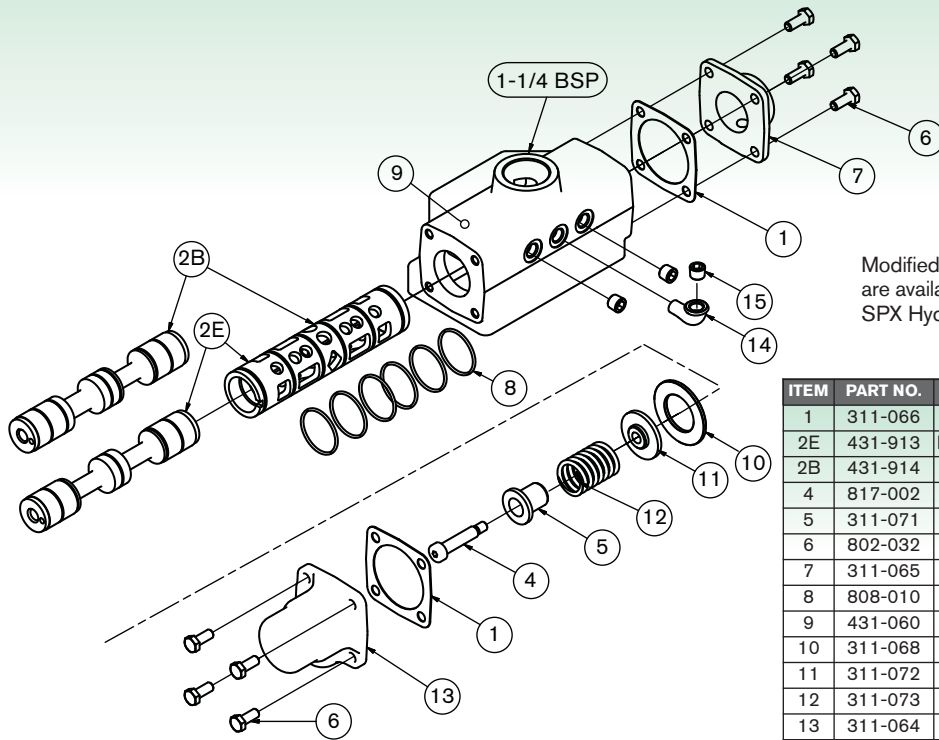

Modified threads and other valve options are available upon request. Please contact SPX Hydraulic Technologies.

ITEM	PART NO.	DESCRIPTION	QTY.
1	311-066	End Cap Gasket	2
2E	431-913	Matched Spool and Sleeve (Equipower)	1
2B	431-914	Matched Spool and Sleeve (Biased)	1
4	817-002	Shoulder Screw 10mm	1
5	311-071	Centering Shaft Guide	1
6	802-032	Hex Head Screw M8 x 20	8
7	311-065	End Cap - Plain End	1
8	808-010	O-Ring 1-9/16" x 1-11/16"	6
9	431-060	Valve Body	1
10	311-068	Valve Sleeve Spacer	1
11	311-072	Washer, Spring Centering	1
12	311-073	Spring, Control Spool	1
13	311-064	End Cap - Spring End	1
14	816-048	Elbow M/F 1/4" BSPT	1
15	816-074	Plug 1/4" BSPT	3

HAND CONTROL VALVE - 1-1/4 BSP PORT

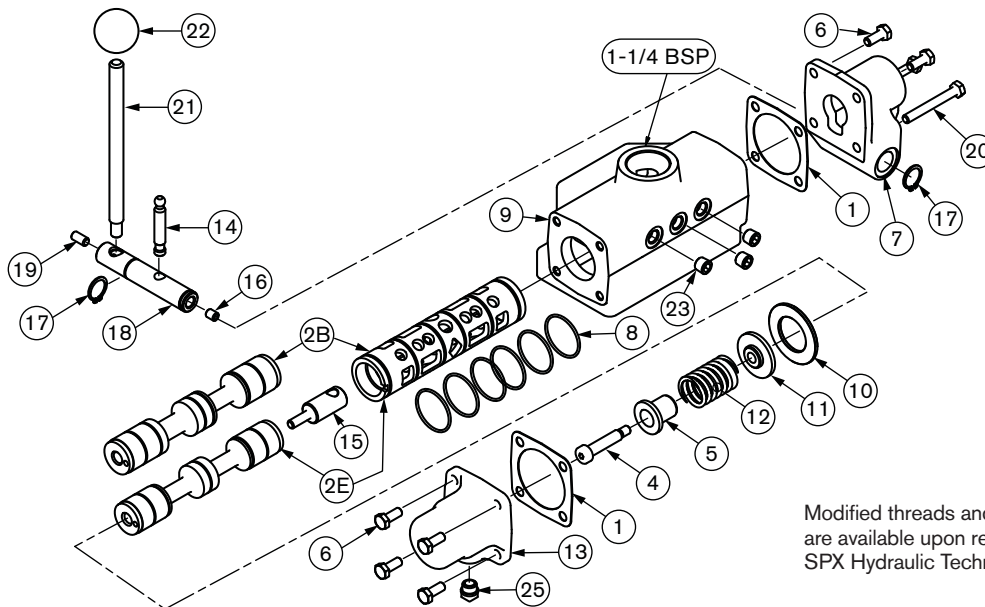

Modified threads and other valve options are available upon request. Please contact SPX Hydraulic Technologies.

ITEM	PART NO.	DESCRIPTION	QTY.
1	311-066	End Cap Gasket	2
2E	431-913	Matched Spool and Sleeve (Equipower)	1
2B	431-914	Matched Spool and Sleeve (Biased)	1
4	817-002	Shoulder Screw 10mm	1
5	311-071	Centering Shaft Guide	1
6	802-032	Hex Head Screw M8 x 20	6
7	313-041	Hand Lever Cap	1
8	808-010	O-Ring 1-9/16"x1-11/16"	6
9	431-060	Valve Body	1
10	311-068	Valve Sleeve Spacer	1
11	311-072	Washer, Spring Centering	1
12	814-015	Spring 343720	1

ITEM	PART NO.	DESCRIPTION	QTY.
13	311-064	End Cap - Spring End	1
14	313-026	Toggle Pin	1
15	313-024	Toggle Shaft	1
16	815-010	Grub Screw M8 x 10	1
17	804-013	Circlip 20mm External	2
18	313-008	Hand Lever Pivot	1
19	815-002	Grub Screw M8 x 16	1
20	802-045	Hex Bolt M8 x 60	2
21	313-002	Hand Lever	1
22	818-002	Black Plastic Knob 1-1/2"	1
23	816-074	Plug 1/4" BSPT Sq. Head	3
25	113-050	Vent Plug	1



RM410 PARKING BRAKE INSTALLATION DETAILS

The brake module bolts directly onto the motor mounting face and has exactly the same interface as the motor. As shown on the drawing below, the brake consists of two spring applied shoes pressed against a central hub. These shoes are released by applying air pressure to the cylinder/piston assembly. The brake torque can be varied by means of two spring adjusters

but it is normally set so that a pilot pressure of 4.1 bar / 60 psi will fully release it. Pressures below this level will progressively reduce the braking torque available. The brakes are set at the plant but it may be necessary to make adjustments on site to suit the individual application.

BRAKE VIEW

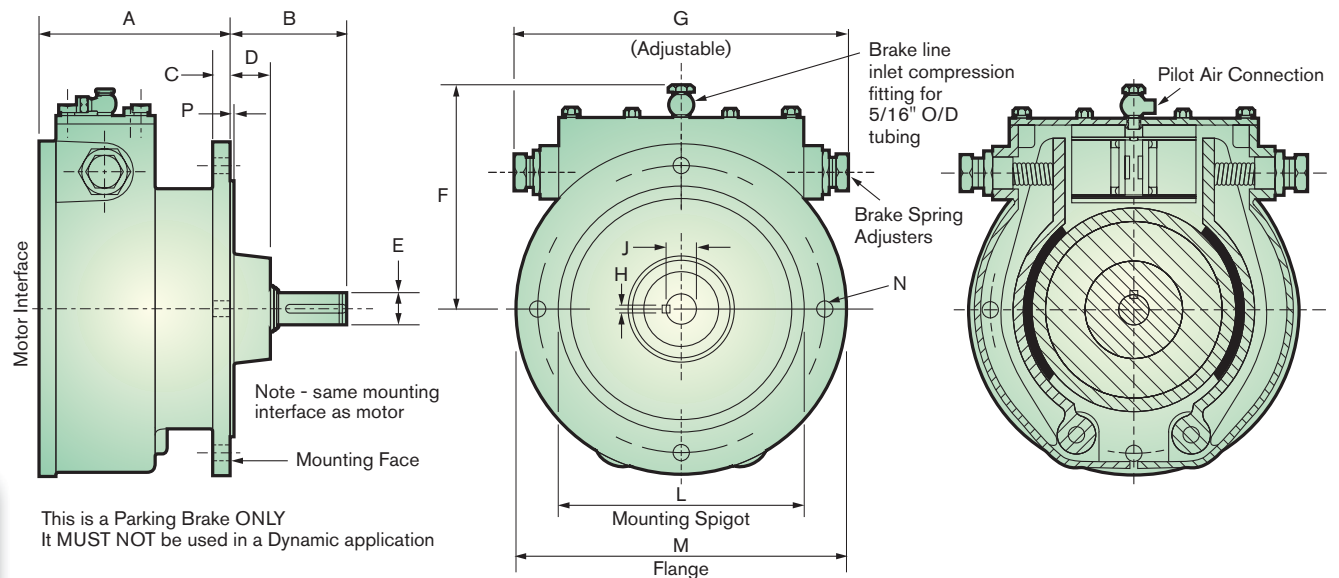

A	B	C	D	E	F	G	P	H	J	L	M	N-MOUNTING HOLES			
												NO.	Ø	P.C.D.	BOLT LENGTH (MAX)
175.26	104.1	16.0	38.1	28.0	205.7	340.3	4.0	8.0	30.8	229.9	304.8	101.6	13.9	264.1	725.8
6.9"	4.1"	0.63"	1.5"	1.1025"	8.1"	13.4"	0.16"	0.314"	1.215"	9.0535"	12.0"	4"	0.55"	10.4"	28.575"

CIRCUITS

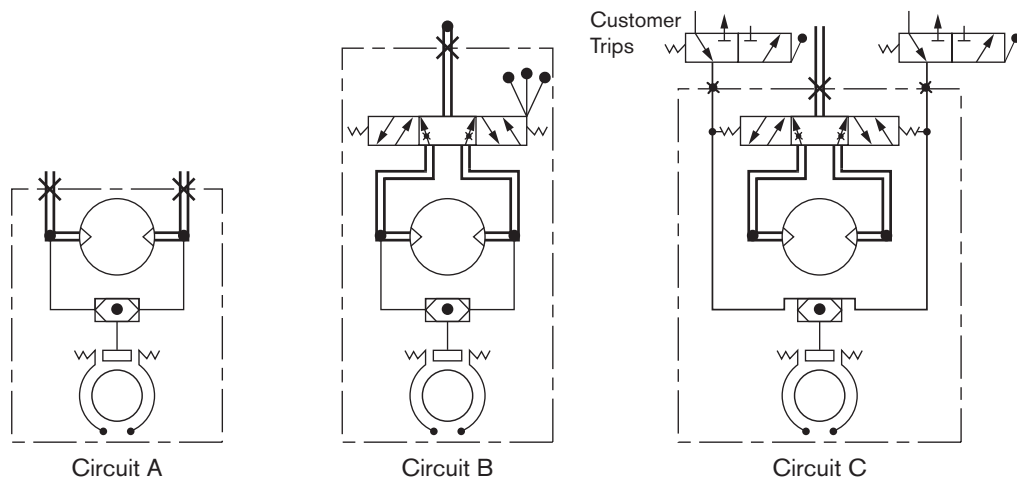

Circuit (A) - Applies to braked motors supplied without control valving. The unit will be fitted with a shuttle valve to allow brake operation for dual rotation.

Circuit (B) - Units supplied with hand (HCV) controlled reversible valves. If trips are required they must be of the mechanical style (customer's supply).

Circuit (C) - Units supplied with remotely controlled valves. When override trips are required, they must be superimposed in the signal line close to the motor unit and be of the 3 way style. (Signal lines cut and exhausted in the tripped position.)

RM410 PARKING BRAKE SPARE PARTS LIST & FOOT BRACKET

PARKING BRAKE SPARE PARTS LIST

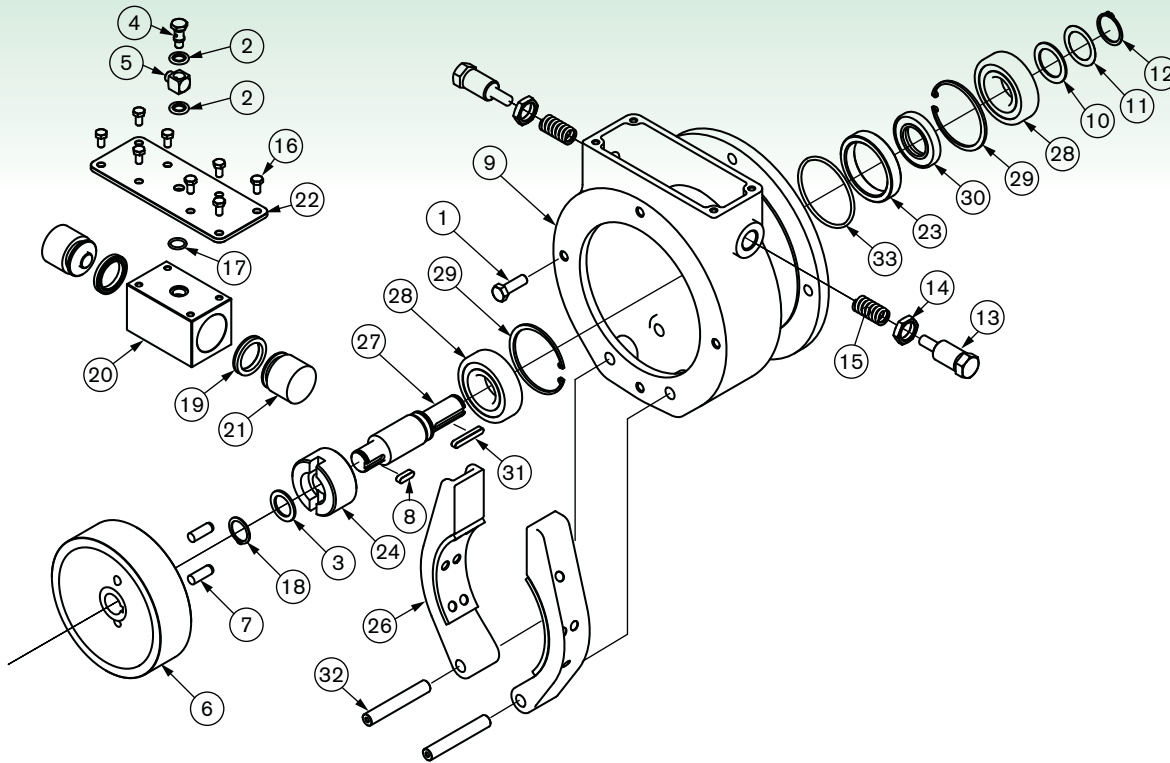

ITEM	PART NO.	DESCRIPTION	QTY.
1	802-073	Set Screw M12 x 30	4
2	808-090	Bonded Seal 1/4" BSP Dowty	2
3	412-034	Spacer - Output Shaft	1
4	816-004	Banjo Bolt Only 1/8" BSP	1
5	816-005	Banjo Body C/W Nut & Pin 5/16"	1
6	412-001	Brake Wheel	1
7	806-002	Dowel Diameter 12 x 35 Lg	2
8	811-004	Key K121	1
9	412-010	Brake Housing	1
10	430-049	Shim - Output	5
11	430-035	Output Shaft Spacer	1
12	804-016	Circlip 38mm External	1
13	412-009	Brake Spring Adjuster	2
14	412-024	Locknut	2
15	814-010	Spring 304114	2
16	802-031	Hex Head Screw M8 x 16	4

ITEM	PART NO.	DESCRIPTION	QTY.
17	808-112	O-Ring 11/16" x 7/8"	1
18	804-010	Circlip 28mm External	2
19	808-076	U Packing 210-319-4490	2
20	412-902A	Piston Block Assembly	1
21	412-011	Brake Piston	2
22	412-013	Block Support Plate	1
23	430-083	Oil Seal Sleeve	1
24	412-131	Brake Shaft Driver	1
26	412-901	Brake Shoe Assembly	2
27	412-133	Brake Shaft	1
28	807-013	Bearing 6308 2RS	2
29	804-068	Circlip 90mm Internal	2
30	808-048	Oilseal 40 x 72 x 10/R21	1
31	811-005	Key K128	1
32	412-003	Brake Shoe Pivot	2
33	808-133	O-Ring 3-1/2" ID x .139	1



FOOT BRACKET

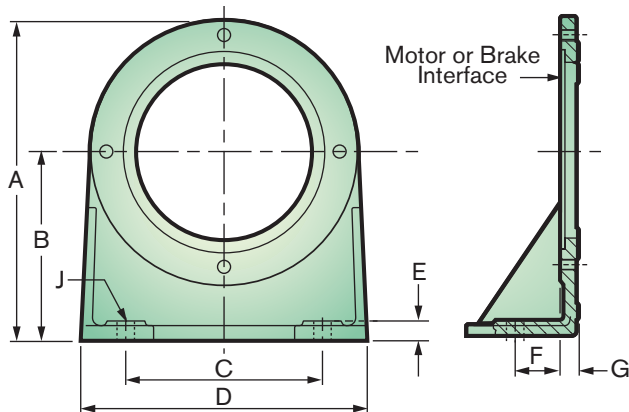

A	B	C	D	E	F	G	H	J
370.8	214.7	228.0	330.2	18.7	52.0	22.8	—	2 x Ø 21.0
14.6"	8.4545"	8.98"	13.0"	0.74"	2.05"	0.9"	—	2 x Ø 0.83"

RM510 PEAK POWER 22kW (31HP) PERFORMANCE DATA

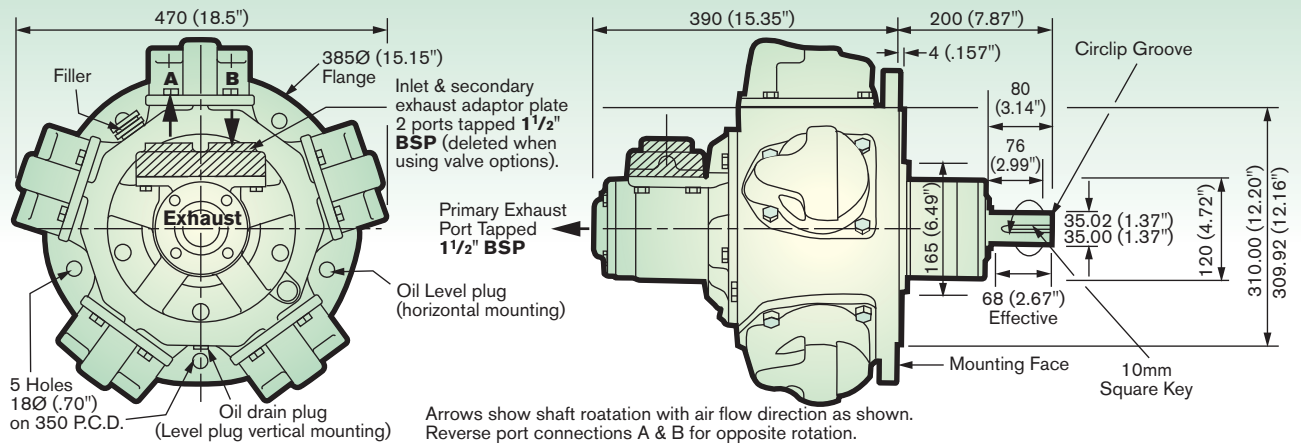

Reading Graphs - Scales have been adjusted to enable bar and psi to be read from a common curve. Therefore only read psi with the left hand axis and bar with the right hand axis.

GRAPH 1 TORQUE - SPEED

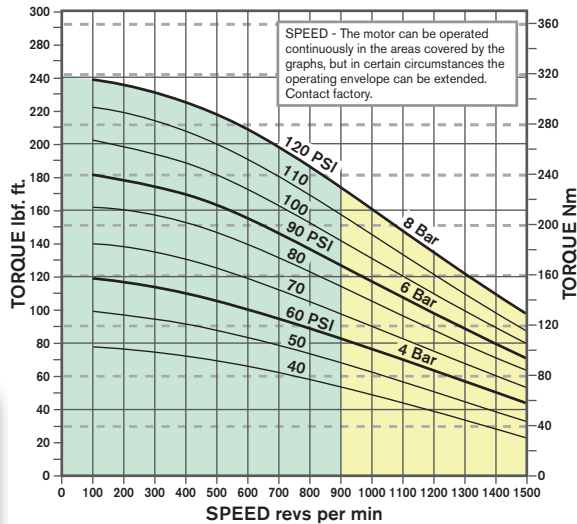

GRAPH 2 STARTING TORQUE - PRESSURE

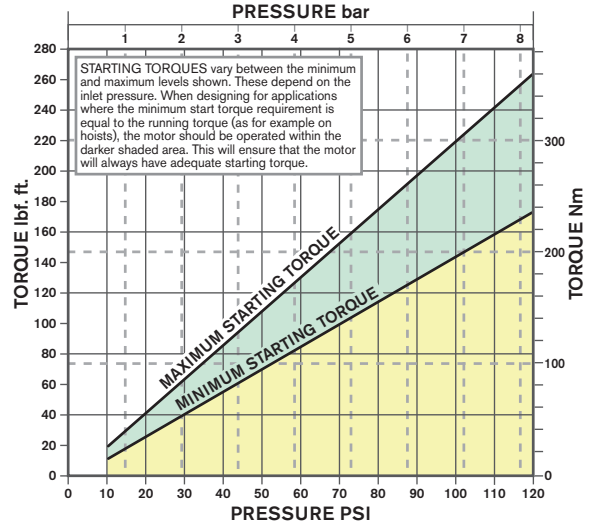

GRAPH 3 POWER - SPEED

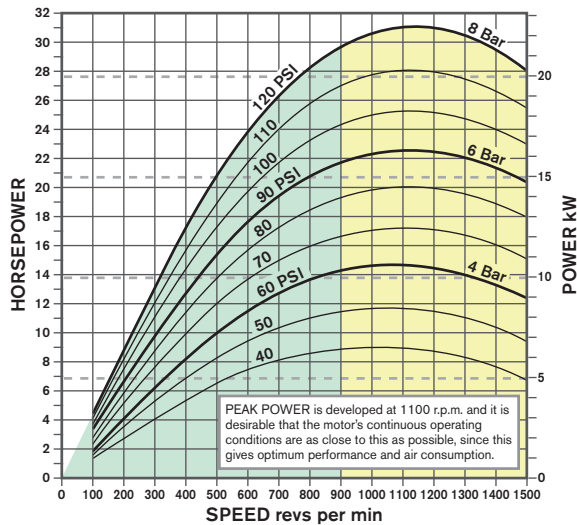

GRAPH 4 CONSUMPTION - SPEED

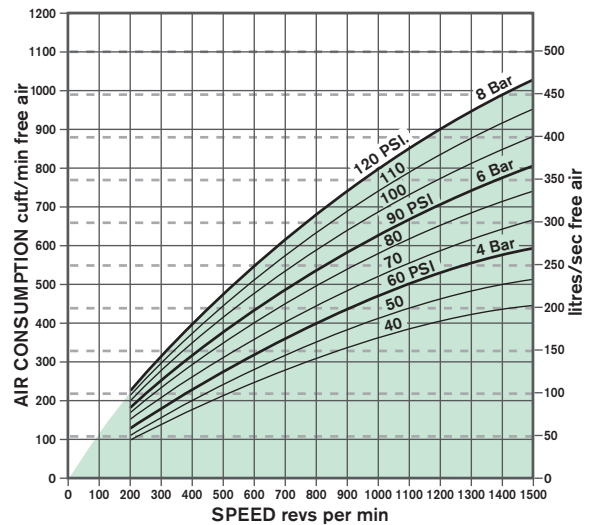

Lubricating Oil Capacities - Horizontal 1.1 litres / 38 fl. oz., Vertical 2.1 litres / 74 fl. oz. Use a good quality hydraulic oil with a viscosity of around 100cSt (460SSU) at 40° C / 104° F.

Airline Filtration and Lubrication - Use 64 micron filtration or better. Choose a lubricator suitable for the flow required. Prior to initial start-up, inject oil into the inlet port. Lubricator drop rate: 3-4 drops/minute continuous operation. Lubricator drop rate 6-10 drop/minute intermittent operation.

General Data -

- Mass** (motor only) 115 kgs / 254 lbs.
- Moment of Inertia** of rotating parts 14 gm² / 48 lb. in² (motor only)
- Max Overhung Force** on motor shaft 6500 N / 1460 lbf.
- Temperature Range** -20° C to +80° C / -4° F to +176° F

RM510 MOTOR SPARE PARTS LIST

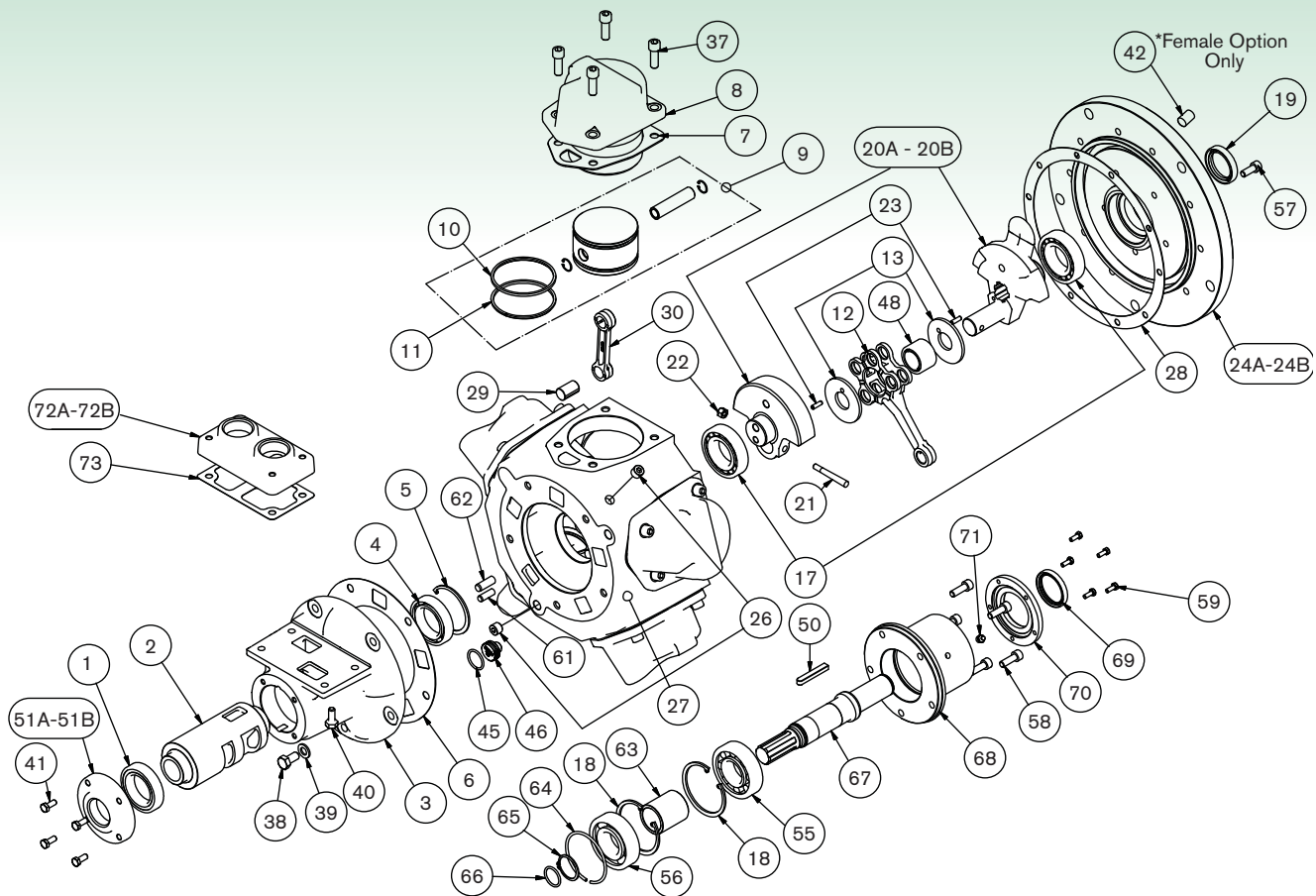

ITEM	PART NO.	DESCRIPTION	QTY.	KIT NO.
1	807-006	Rotary Valve Bearing (Outer)	1	
2	520-006	Rotary Valve	1	
3	520-011	Rotary Valve Housing	1	
4	807-005	Rotary Valve Bearing (Inner)	1	
5	804-066	Rotary Valve Bearing Circlip	1	
6	510-001	Rotary Valve Housing Gasket	1*	529-911
7	510-030	Cylinder Gasket	5*	529-911
8	510-082	Cylinder	5	
9	520-902A	Piston Assembly	5	
10	520-024	Compression Ring	5*	529-911
11	520-022	Oil Control Ring	5*	529-911
12	520-077	King Rod	1	
13	520-052	Crankshaft Spacer	2	
17	807-062	Crankshaft Bearing	2	
18	804-068	Crankshaft Bearing Circlip	2	
19	808-047	Crankshaft Oilseal	1*	529-911
20A	520-901	Std. Crankshaft Assembly	1	
20B	520-904	SAE Crankshaft Assembly	1	
21	510-088	Crank Bolt	1	
22	801-009	Crank Nut	1	
23	806-013	Spring Dowel	2	
24A	520-076	Std. Flange Plate	1	
24B	520-113	SAE Flange Plate	1	
26	816-071	Plug	1	
27	520-012	Engine Case	1	
28	510-090	Engine Case Gasket (520)	1*	529-911
29	520-081	Queen Rod Pivot	3	
30	520-078	Queen Rod	3	
37	809-035	Cylinder Bolts	20	
38	802-073	Valve Housing Bolts	4	
39	803-015	Washer for Item #38		

ITEM	PART NO.	DESCRIPTION	QTY.	KIT NO.
40	802-054	Adaptor Plate Bolt	4	
41	802-033	Exhaust Cover Bolts	4	
42	815-008	Flange Plate Plugs	5	
45	808-004	Seal (transit only)	1	
46	130-066	Breather Plug	1	
48	807-047	Needle Bearing	1	
50	811-030	Key	1	
51A	520-005	Rotary Valve Exhaust Cover BSP	1	
51A	520-105	Rotary Valve Exhaust Cover NPT	1	
55	807-063	Output Shaft Bearing (Outer)	1	
56	807-012	Output Shaft Bearing (Inner)	1	
57	809-001	Flange Plate Cap Screws	10	
58	809-002	Output Housing Bolts	5	
59	802-016	Output Housing Cover Bolts	5	
61	806-011	Drive Pin (Dia. 10mm)	1	
62	806-022	Drive Pin (Dia. 12mm)	1	
63	518-001	Output Shaft Bearing Spacer	1	
64	518-004	Output Shaft Spring Ring	1	
65	804-017	Output Shaft Circlip	1	
66	804-004	Output Shaft Seal	1*	529-911
67	518-003	Output Shaft	1	
68	518-005	Output Shaft Housing	1	
69	808-042	Output Shaft Oil Seal	1*	
70	518-002	Output Shaft Housing Cover	1	
71	816-015	Output Shaft Grease Nipple	1	
72A	520-003	Inlet Adaptor Plate BSP	1	
72B	520-103	Inlet Adaptor Plate NPT	1	
73	430-004	Inlet Adaptor Plate Gasket	1*	529-911
	529-911	Seal Kit	1	

Please note item 529-911 (Seal Kit) includes all items marked thus:*



RM510 GEARED MOTOR INSTALLATION DETAILS

Maximum performance details listed below are at 6 bar / 90 psi. The performance under different conditions can be obtained by using the curves on page 36. A typical minimum gearbox efficiency of 90% can be expected. For higher pressures contact SPX Hydraulic Technologies.

The maximum overhung force is assumed acting midway along the output shaft; for other positions or higher loads on intermittent applications; contact SPX Hydraulic Technologies.

PERFORMANCE SUMMARY

GEARBOX RATIO	MAXIMUM POWER CONDITIONS					APPROX. MIN. START TORQUE		MAX. CONT. rmp	MAX. OVERHUNG FORCE		WEIGHT			
	kW	hp	rpm	TORQUE		Nm	lbf. ft		N	lbf.	GEARBOX	ADAPTER	GEARBOX KIT	MOTOR & GEARBOX
				Nm	lbf. ft									
5.24	16	22.5	210	734	541	807	596	281	13870	3118	85	18	103	218
25.05	16	22.5	44	3507	2588	3858	2847	59	45000	10117	215	18	233	348
50.74	16	22.5	22	7104	5243	7814	5767	29	50000	11241	305	18	323	438
92.06	16	22.5	12	12888	9512	14177	10463	16	120000	26978	635	18	653	768

For additional types and ratios contact SPX Hydraulic Technologies.

BASE MOUNTED GEAR BOX DIMENSIONS

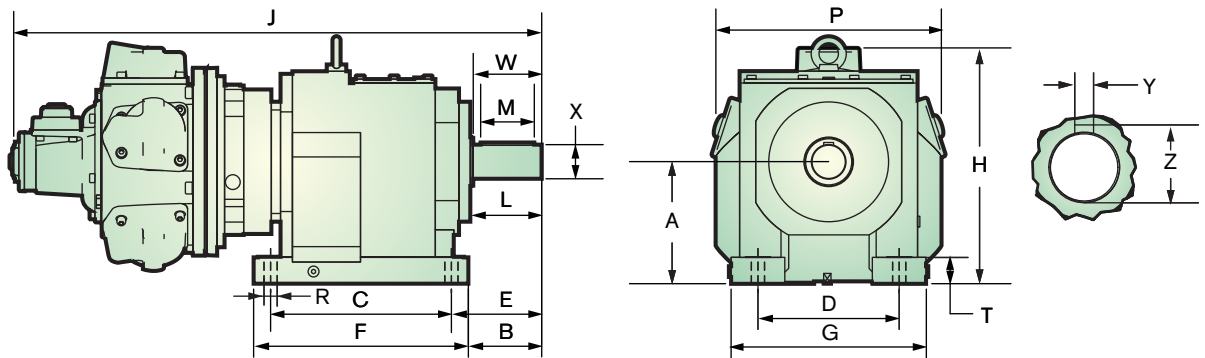

RANGE RATIO	A	B	C	D	E	F	G	H	J	L	M	P	R	T	W	X	Y	Z	MASS
3.42 - 12.68:1	225 8.9"	132 5.2"	310 12.2"	250 9.8"	159.5 6.3"	365 14.4"	340 13.4"	469 18.5"	1131 44.5"	125 4.9"	100 3.9"	410 16.1"	22 0.9"	50 2.0"	120 4.7"	60.02 2.4"	18 0.7"	64 2.5"	218 kg 481 lb
14.06 - 21.41:1	250 9.8"	150 5.9"	370 14.6"	290 11.4"	185 7.3"	440 17.3"	400 15.7"	507 20.0"	1092 43.0"	145 5.7"	110 4.3"	462 18.2"	26 1.02"	55 2.2"	140 5.5"	70.02 2.8"	20 0.8"	74.5 2.9"	348 kg 767 lb
23.04 - 35.09:1	315 12.4"	220 8.7"	410 16.1"	340 13.4"	260 10.2"	490 19.3"	450 17.7"	578 22.8"	1199 47.2"	216 8.5"	180 7.1"	510 20.1"	33 1.3"	60 2.4"	210 8.3"	100.03 3.9"	28 1.1"	106 4.2"	438 kg 966 lb
39.45 - 63.08:1	355 14.0"	215 8.5"	500 19.7"	380 15.0"	260 10.2"	590 23.2"	530 20.9"	660 26.0"	1305 51.4"	216 8.5"	180 7.1"	580 22.8"	39 1.5"	65 2.6"	210 8.3"	100.03 3.9"	28 1.1"	106 4.2"	608 kg 1340 lb
69.41 - 92.06:1	425 16.7"	225 8.9"	580 22.8"	500 19.7"	270 10.6"	670 26.4"	630 24.8"	758 29.8"	1373 54.1"	216 8.5"	180 7.1"	630 24.8"	39 1.5"	100 3.9"	210 8.3"	120.03 4.7"	32 1.3"	127 5.0"	768 kg 1693 lb

FLANGE MOUNTED GEAR BOX DIMENSIONS

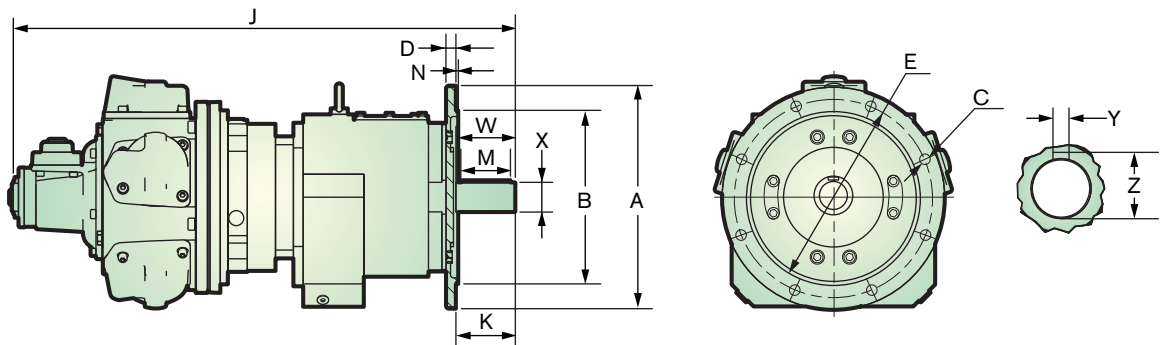

RANGE RATIO	A	B	C	D	E	J	K	M	N	W	X	Y	Z	MASS
3.42 - 12.68:1	450 17.7"	350.00 13.8"	17.5 0.7"	20 0.8"	400 15.7"	1020 40.2"	120 4.7"	100 3.9"	5 0.2"	120 4.7"	60.02 2.4"	18 0.7"	64 2.5"	218 kg 481 lb
14.06 - 21.41:1	450 17.7"	350.00 13.8"	17.5 0.7"	22 0.9"	400 15.7"	1103 43.4"	140 5.5"	110 4.3"	5 0.2"	140 5.5"	70.02 2.8"	20 0.8"	74.5 2.9"	348 kg 767 lb
23.04 - 35.09:1	450 17.7"	350.00 13.8"	17.5 0.7"	22 0.9"	400 15.7"	1170 46.1"	170 6.7"	140 5.5"	5 0.2"	210 8.3"	90.03 3.5"	25 1.0"	95 3.7"	438 kg 966 lb
39.45 - 63.08:1	550 21.7"	450.00 17.7"	18 0.7"	31 1.2"	500 19.7"	1305 51.4"	210 8.3"	180 7.1"	5 0.2"	210 8.3"	100.03 3.9"	28 1.1"	106 4.2"	608 kg 1340 lb
69.41 - 92.06:1	550 21.7"	450.00 17.7"	18 0.7"	31 1.2"	500 19.7"	1392 54.8"	210 8.3"	180 7.1"	5 0.2"	210 8.3"	120.03 4.7"	32 1.3"	127 5.0"	768 kg 1693 lb

Detailed drawings and CAD models available on request. Ratios above the basic range shown are available on request. Alternative gearbox types and arrangements i.e. right angle output, hollow shaft etc. also available.

Modified dimensions for shafts and flanges available on request.

RM510 VALVE OPTIONS

This range of bolt on valves offers very sensitive speed and directional control. One frictionless matched spool and sleeve assembly is offered with two alternative means of actuation.

CONFIGURATION

As standard these valves can be supplied with either EQUAL POWER or BIASED POWER spools, the latter is suitable for hoisting applications (normal power for lifting - reduced power for lowering).

The direction of reduced power must be stated when ordering CW or CCW, when viewed on the output shaft of the motor or geared motor.

1. Remotely Controlled (RCV) - This option is usually controlled from a remote position by one of the PC series or LC2 units. A variable air pilot signal is

applied to either end of the valve spool, depending on the required direction of motor rotation. The pilot pressure range is between 1.4 bar / 20 psi and 4.8 bar / 70 psi, increased pilot pressure give increased speed. The valve is spring centered to neutral.

2. Hand Controlled (HCV) - The control valve spool is operated directly by a lever mechanism. Speed increase is obtained as the lever is moved in either direction from the center (neutral) position.

Pressure Drop - Minimal pressure drop will be experienced through the valves, having the effect of maintaining the output torque while reducing the motor output speed by approximately 10-15% at 6 bar / 90 psi at maximum power. The starting torque remains unaffected.

REMOTE CONTROL VALVE - 1-1/2 BSP PORTS

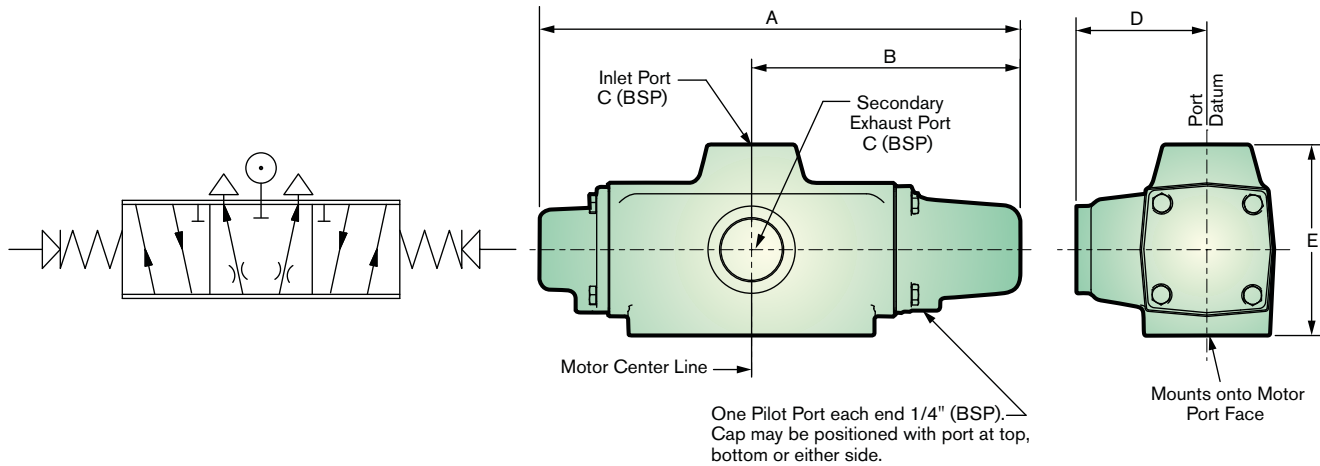

Modified threads and other valve options are available upon request. Please contact SPX Hydraulic Technologies.

A	B	C (BSP)	D	E	Approx. WT.
355.6	198.1	1-1/2	96.5	137.1	13.6 kg
14.0"	7.8"		3.8"	5.4"	30.11 lb



HAND CONTROL VALVE - 1-1/2 BSP PORTS

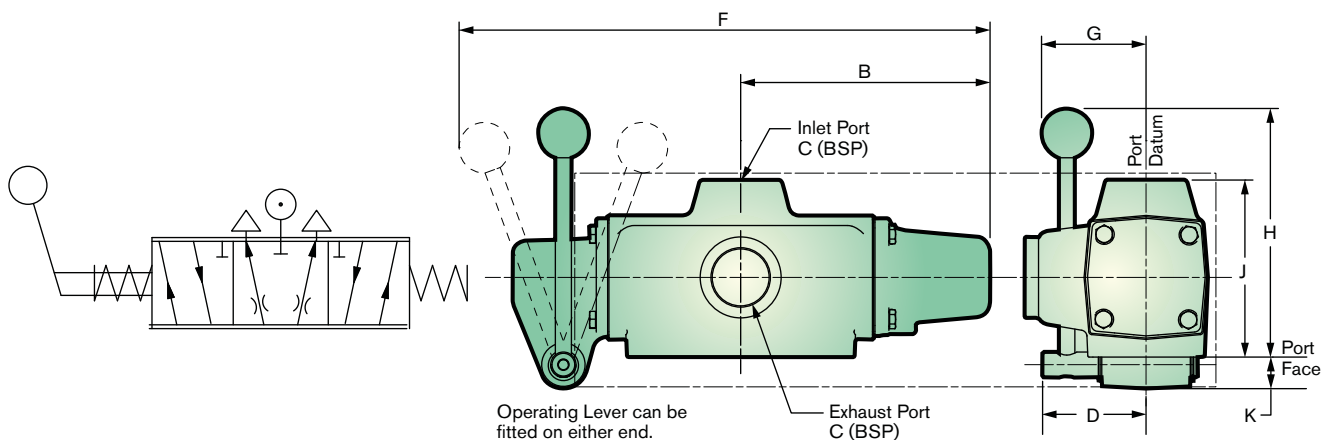

Modified threads and other valve options are available upon request. Please contact SPX Hydraulic Technologies.

B	C (BSP)	D	F	G	H	J	K	Approx. WT.
198.1	1-1/2	96.5	414.0	86.3	190.5	137.1	27.9	13.6 kg
7.8"		3.8"	16.3"	3.4"	7.5"	5.4"	1.1"	30.11 lb

RM510 VALVE OPTIONS SPARE PARTS LISTS

REMOTE CONTROL VALVE - 1-1/2 BSP PORTS

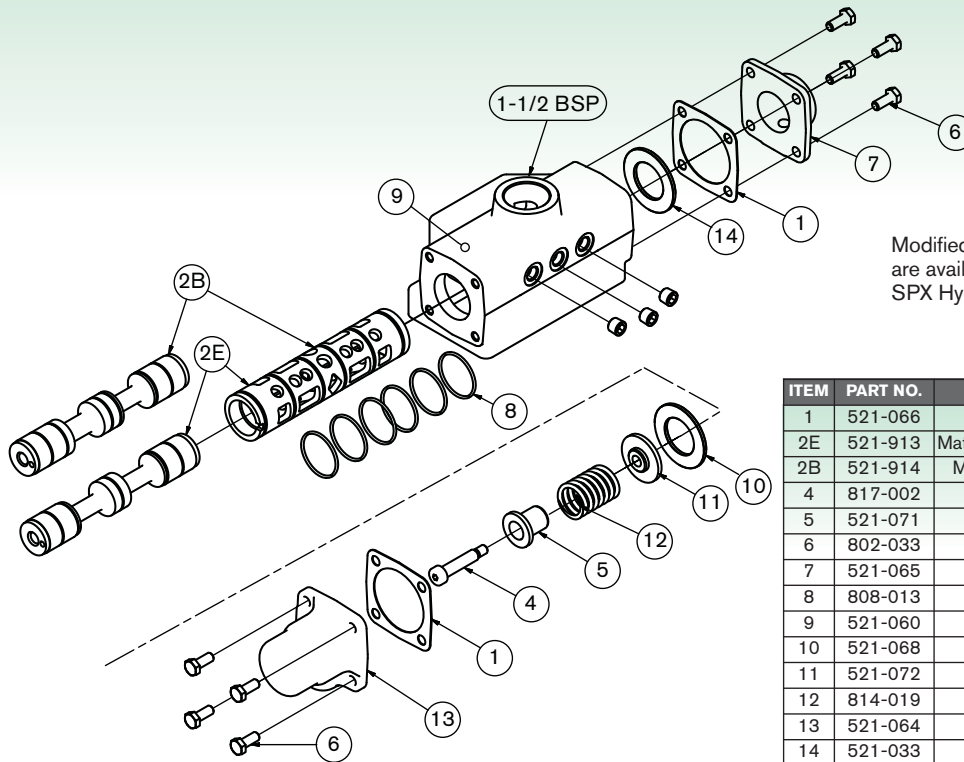

Modified threads and other valve options are available upon request. Please contact SPX Hydraulic Technologies.

ITEM	PART NO.	DESCRIPTION	QTY.
1	521-066	End Cap Gasket	2
2E	521-913	Matched Spool and Sleeve (Equipower)	1
2B	521-914	Matched Spool and Sleeve (Biased)	1
4	817-002	Shoulder Screw 10mm	1
5	521-071	Centering Shaft Guide	1
6	802-033	Hex Head Screw M8 x 25	8
7	521-065	End Cap - Plain End	1
8	808-013	O-Ring 2" x 2-1/8"	6
9	521-060	Valve Body	1
10	521-068	Valve Sleeve Spacer	1
11	521-072	Washer, Spring Centering	1
12	814-019	Spring, Control Spool	1
13	521-064	End Cap - Spring End	1
14	521-033	End Cap Washer	1
15	816-074	Plug 1/4" BSPT	3

HAND CONTROL VALVE - 1-1/2 BSP PORTS

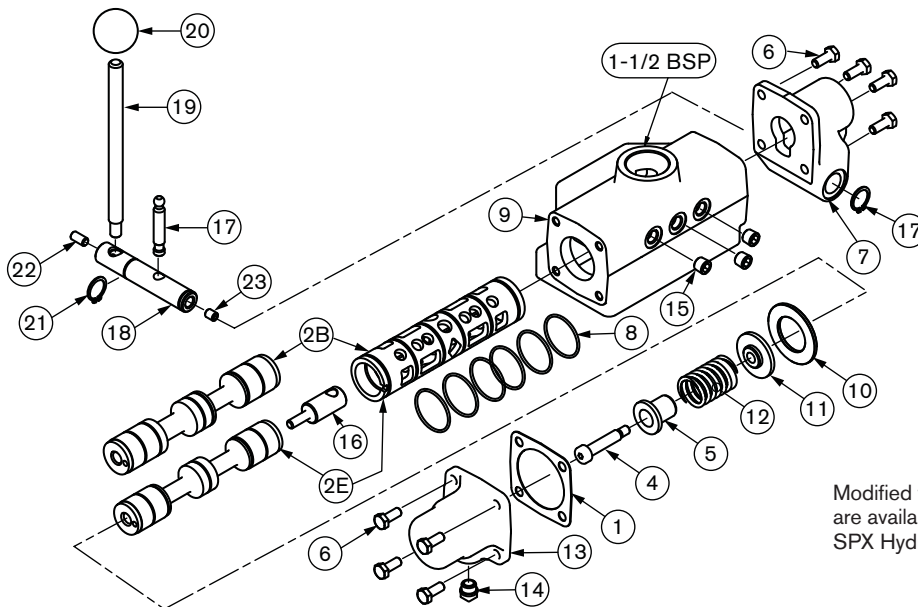

Modified threads and other valve options are available upon request. Please contact SPX Hydraulic Technologies.

ITEM	PART NO.	DESCRIPTION	QTY.
1	521-066	End Cap Gasket	1
2E	521-913	Matched Spool and Sleeve (Equipower)	1
2B	521-914	Matched Spool and Sleeve (Biased)	1
4	817-002	Shoulder Screw 10mm	1
5	521-071	Centering Shaft Guide	1
6	802-033	Hex Head Screw M8 x 25	8
7	523-041	Lever Cap	1
8	808-013	O-Ring 2" x 2-1/8"	6
9	521-060	Valve Body	1
10	521-068	Valve Sleeve Spacer	1
11	521-072	Washer, Spring Centering	1
12	814-020	Spring Flexo 403824	1

ITEM	PART NO.	DESCRIPTION	QTY.
13	521-064	End Cap - Spring End	1
14	113-050	Vent Plug	1
15	816-074	Plug 1/4" BSPT	3
16	523-024	Toggle Shaft	1
17	523-026	Toggle Pin	1
18	523-008	Hand Lever Pivot	1
19	313-002	Hand Lever	1
20	818-002	Black Plastic Knob 1-1/2"	1
21	804-013	Circlip 20mm External	2
22	815-010	Grub Screw M8 x 10	1
23	815-002	Grub Screw M8 x 16	1

RM510 PARKING BRAKE INSTALLATION DETAILS

The brake module bolts directly onto the motor mounting face and has exactly the same interface as the motor. As shown on the drawing below, the brake consists of two spring applied shoes pressed against a central hub. These shoes are released by applying air pressure to the cylinder/piston assembly. The brake torque can be varied by means of two spring adjusters

but it is normally set so that a pilot pressure of 4.1 bar / 60 psi will fully release it. Pressures below this level will progressively reduce the braking torque available. The brakes are set at the plant but it may be necessary to make adjustments on site to suit the individual application.

BRAKE VIEW

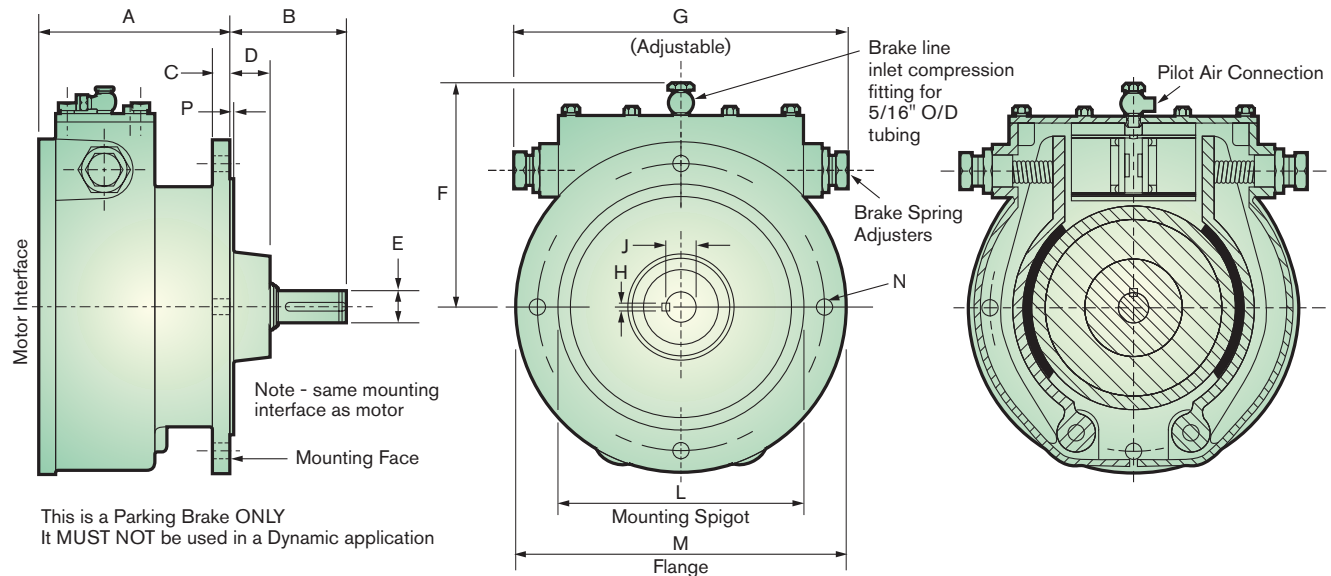

A	B	C	D	E	F	G	P	H	J	L	M	N-MOUNTING HOLES			
												NO.	Ø	P.C.D.	BOLT LENGTH (MAX)
172.7	96.5	16.0	16.0	34.7	269.2	449.5	5.0	9.9	37.8	309.9	386.0	127.0	18.0	350.5	38.1
6.8"	3.8"	0.63"	0.63"	1.3785"	10.6"	17.7"	0.2"	0.393"	1.4905"	12.2035"	15.2"	5"	0.71"	13.8"	1-1/2"

CIRCUITS

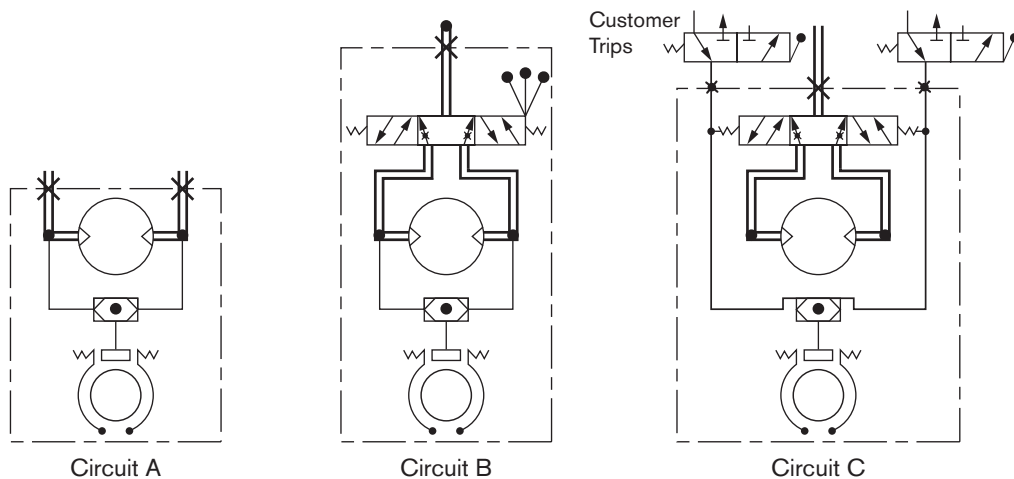

Circuit (A) - Applies to braked motors supplied without control valving. The unit will be fitted with a shuttle valve to allow brake operation for dual rotation.

Circuit (B) - Units supplied with hand (HCV) controlled reversible valves. If trips are required they must be of the mechanical style (customer's supply).

Circuit (C) - Units supplied with remotely controlled valves. When override trips are required, they must be superimposed in the signal line close to the motor unit and be of the 3 way style. (Signal lines cut and exhausted in the tripped position.)



RM510

PARKING BRAKE SPARE PARTS LIST & FOOT BRACKET

PARKING BRAKE SPARE PARTS LIST

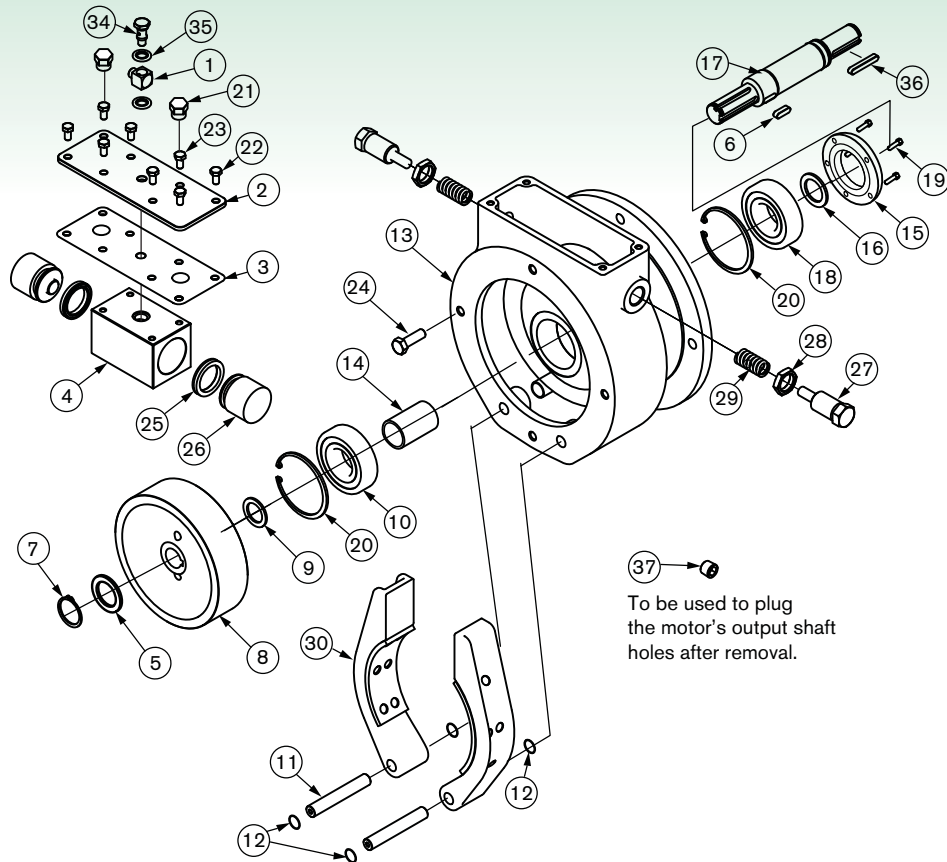

ITEM	PART NO.	DESCRIPTION	QTY.
1	816-005	Banjo Body C/W Nut & Pin 5/16"	1
2	512-013	Plunger Plate	1
3	512-030	Gasket Plunger Block	1
4	512-021	Plunger Block	1
5	804-017	Circlip 40mm External	2
6	811-006	Key K130	1
7	808-002	O-Ring - 1/8" x 1-3/8"	1
8	512-001	Brake Wheel	1
9	512-036	Wheel Spacer	1
10	807-013	Bearing 6308 2RS	1
11	412-003	Pin	2
12	803-003	Washer M16	6
13	512-008	Brake Housing	1
14	518-001	Output Bearing Spacer	1
15	518-002	Output Bearing Housing Cap	1
16	808-042	Oilseal 48 x 62 x 8/R4	1
17	512-005	Brake Shaft	1

ITEM	PART NO.	DESCRIPTION	QTY.
18	807-063	Roller Bearing	1
19	802-016	Hex Head Screw M6 x 16	5
20	804-068	Circlip 90mm External	3
21	816-265	Screw Plugs (Bluemay)	2
22	802-053	Set Screw M10 x 25	4
23	802-052	Set Screw M10 x 20	4
24	802-094	Bolt M6 x 40 Hex Head	5
25	808-071	U Packing U132	2
26	512-011	Plunger	2
27	512-009	Adjuster Screw	2
28	512-024	Locknut	2
29	814-011	Spring MSD15	2
30	512-901	Brake Shoe Assembly	2
34	816-006	Banjo Bolt 1/4" BSP	1
35	808-090	Bonded Seal 1/4" BSP Dowty	2
36	811-030	Key 10 x 8 x 63	1
37	815-010	Grub Screw M8 x 10	5

FOOT BRACKET

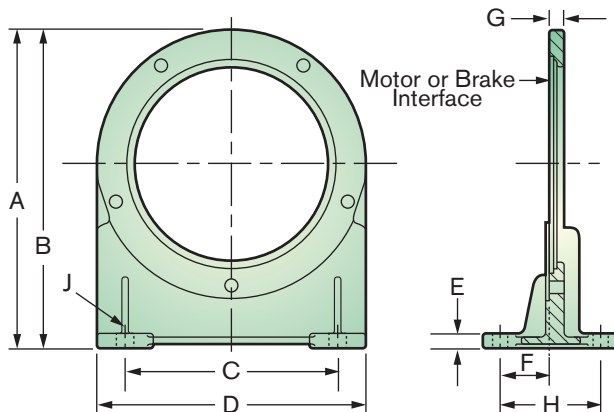

A	B	C	D	E	F	G	H	J
457.2	264.0	304.8	386.0	22.8	70.1	22.8	146.0	4 x Ø 18.0
18.0"	10.394"	12.00"	15.2"	0.9"	2.76"	0.9"	5.75"	4 x Ø 0.71"

RM610

PEAK POWER 23kW (32HP) PERFORMANCE DATA

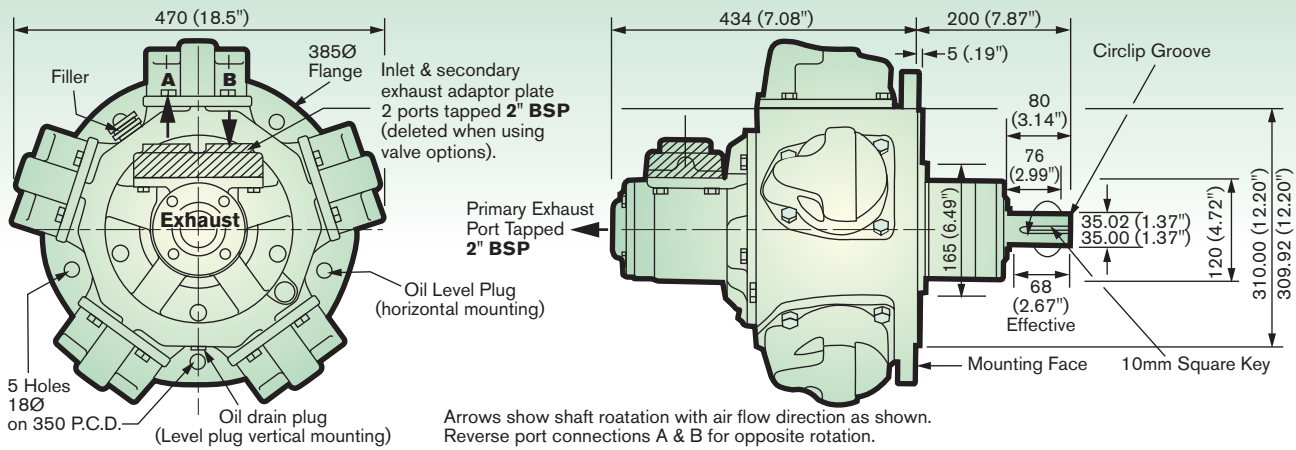

Reading Graphs - Scales have been adjusted to enable bar and psi to be read from a common curve. Therefore only read psi with the left hand axis and bar with the right hand axis.

GRAPH 1 TORQUE - SPEED

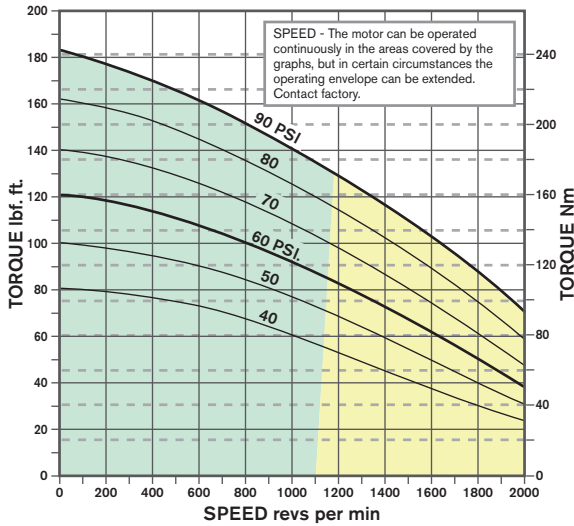

GRAPH 2 STARTING TORQUE - PRESSURE

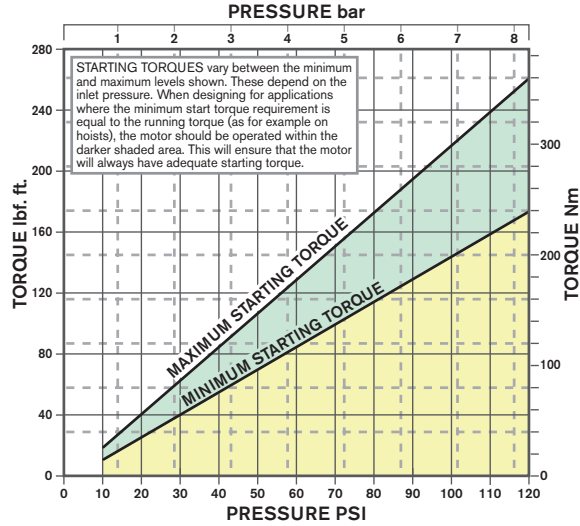

GRAPH 3 POWER - SPEED

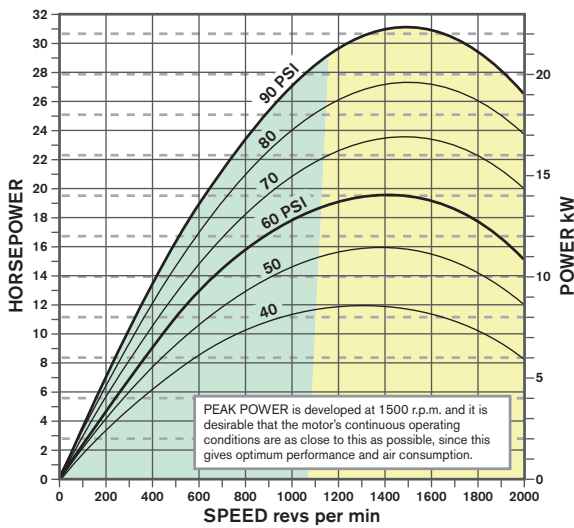

GRAPH 4 CONSUMPTION - SPEED

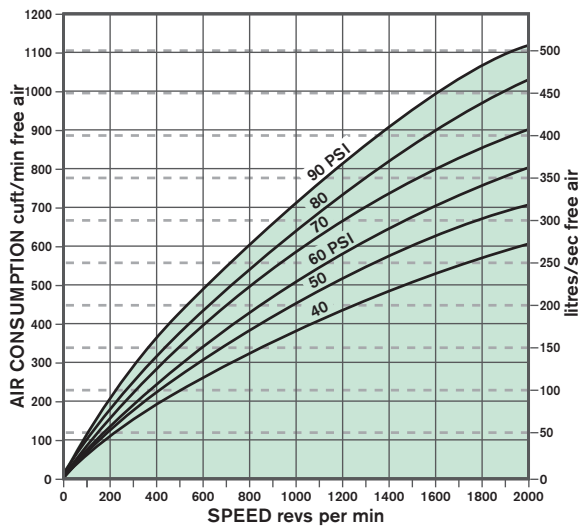

Lubricating Oil Capacities - Horizontal 1.1 litres / 38 fl. oz., Vertical 2.1 litres / 74 fl. oz. Use a good quality hydraulic oil with a viscosity of around 100cSt (460SSU) at 40° C / 104° F.

Airline Filtration and Lubrication - Use 64 micron filtration or better. Choose a lubricator suitable for the flow required. Prior to initial start-up, inject oil into the inlet port. Lubricator drop rate: 3-4 drops/minute continuous operation. Lubricator drop rate 6-10 drop/minute intermittent operation.

General Data -

- Mass** (motor only) 125 kgs / 276 lbs.
- Moment of Inertia** of rotating parts 14 gm² / 48 lb. in² (motor only)
- Max Overhung Force** on motor shaft 6500 N / 1460 lbf.
- Temperature Range** -20° C to +80° C / -4° F to +176° F



RM610 MOTOR SPARE PARTS LIST

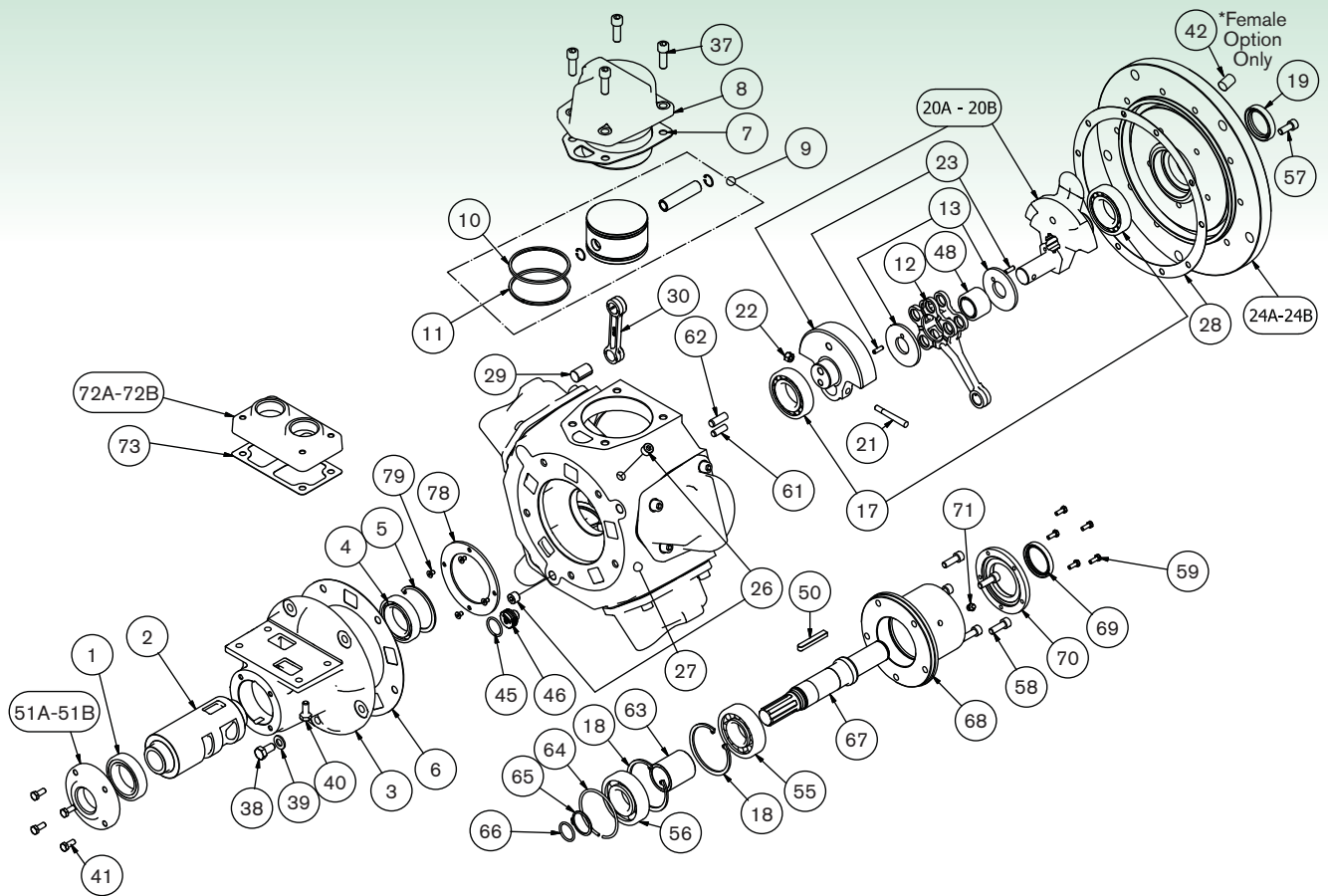

ITEM	PART NO.	DESCRIPTION	QTY.	KIT NO.
1	807-056	Rotary Valve Bearing (Outer)	1	
2	620-006	Rotary Valve	1	
3	620-011	Rotary Valve Housing	1	
4	807-055	Rotary Valve Bearing (Inner)	1	
5	804-070	Rotary Valve Bearing Circlip	1	
6	620-001	Rotary Valve Housing Gasket	1*	629-912
7	510-030	Cylinder Gasket	5*	629-912
8	510-082	Cylinder	5	
9	520-902A	Piston Assembly	5	
10	520-024	Compression Ring	5*	629-912
11	520-022	Oil Control Ring	5*	629-912
12	520-077	King Rod	1	
13	520-052	Crank Pin Spacer	2	
17	807-062	Crankshaft Bearing	2	
18	804-068	Crankshaft Bearing Circlip	2	
19	808-047	Crankshaft Oilseal	1*	629-912
20A	520-901	Std. Crankshaft Assembly	1	
20B	520-904	SAE Crankshaft Assembly	1	
21	510-088	Crank Bolt	1	
22	801-009	Crank Nut	1	
23	806-013	Spring Dowel	1	
24A	520-076	Std. Flange Plate	1	
24B	520-113	SAE Flange Plate	1	
26	816-071	Plug	1	
27	620-012	Engine Case	1	
28	510-090	Engine Case Gasket (520)	1*	629-912
29	520-081	Queen Rod Pivot	5	
30	520-078	Queen Rod	5	
37	809-035	Cylinder Bolts	20	
38	802-054	Valve Housing Bolts	4	
40	802-002	Adaptor Plate Bolt	4	
41	802-033	Exhaust Cover Bolts	2	
42	815-008	Flange Flange Plugs	5*	
45	808-004	Seal (transit only)	1	
46	130-066	Breather Plug	1	

ITEM	PART NO.	DESCRIPTION	QTY.	KIT NO.
48	807-047	Needle Bearing	1	
50	811-030	Key	1	
51A	620-042	Rotary Valve Exhaust Cover BSP	1	
51B	620-042N	Rotary Valve Exhaust Cover NPT	1	
55	807-063	Output Shaft Brg. (Outer)	1	
56	807-012	Output Shaft Brg. (Inner)	1	
57	809-001	Flange Flange Cap Screws	10	
58	809-002	Output Housing Bolts	5	
59	802-016	Output Housing Cover Bolts	5	
61	806-001	Drive Pin (dia. 10mm)	1	
62	806-002	Drive Pin (dia. 12mm)	1	
63	518-001	Output Shaft Bearing Spacer	1	
64	518-004	Output Shaft Spring Ring	1	
65	804-017	Output Shaft Circlip	1	
66	808-004	Output Shaft Seal	1*	629-912
67	518-003	Output Shaft	1	
68	518-005	Output Shaft Housing	1	
69	808-042	Output Shaft Oil Seal	1*	629-912
70	518-002	Output Shaft Housing Cover	1	
71	816-015	Output Shaft Grease Nipple	1	
72A	620-046	Inlet Adaptor Plate BSP	1	
72B	620-046N	Inlet Adaptor Plate NPT	1	
73	130-004	Inlet Adaptor Plate Gasket	1*	629-912
	629-912	Seal Kit	1	
78	620-045	Bearing Cap	1	
79	810-016	Bearing Cap C'sk Screw	4	
	149-920	Conversion Kit		

Please note item 629-912 (Seal Kit) includes all items marked thus:*

RM610 GEARED MOTOR INSTALLATION DETAILS

Maximum performance details listed below are at 6 bar / 90 psi. The performance under different conditions can be obtained by using the curves on page 43. A typical minimum gearbox efficiency of 90% can be expected. For higher pressures contact SPX Hydraulic Technologies.

The maximum overhung force is assumed acting midway along the output shaft; for other positions or higher loads on intermittent applications; contact SPX Hydraulic Technologies.

PERFORMANCE SUMMARY

GEARBOX RATIO	MAXIMUM POWER CONDITIONS						APPROX. MIN. START TORQUE	MAX. CONT. rmp	MAX. OVERHUNG FORCE		WEIGHT				
	kW	hp	rpm	TORQUE		N			lbf.	N	lbf.	GEARBOX	ADAPTER	GEARBOX KIT	MOTOR & GEARBOX
				Nm	lbf. ft										
5.24	16	22.5	210	734	541	807	596	281	13870	3118	85	18	103	218	
25.05	16	22.5	44	3507	2588	3858	2847	59	45000	10117	215	18	233	348	
50.74	16	22.5	22	7104	5243	7814	5767	29	50000	11241	305	18	323	438	
92.06	16	22.5	12	12888	9512	14177	10463	16	120000	26978	635	18	653	768	

For additional types and ratios contact SPX Hydraulic Technologies.

BASE MOUNTED GEAR BOX DIMENSIONS

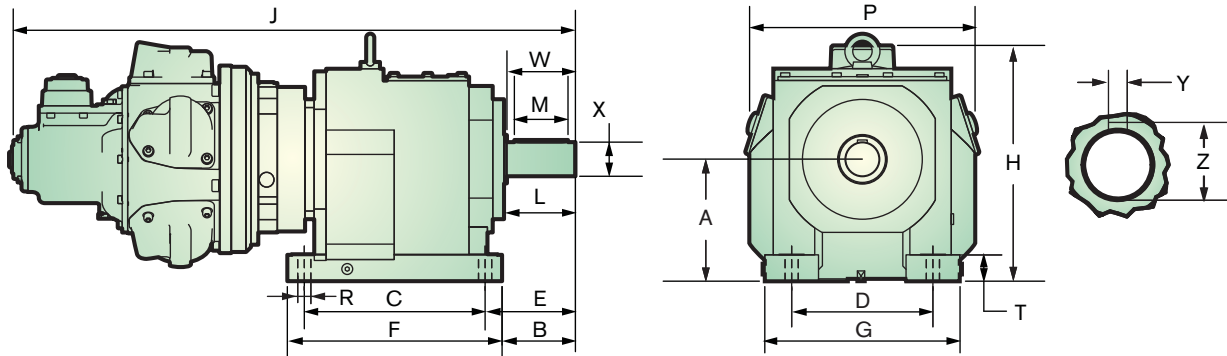

RANGE RATIO	A	B	C	D	E	F	G	H	J	L	M	P	R	T	W	X	Y	Z	MASS
3.42 - 12.68:1	225	132	310	250	159.5	365	340	469	1131	125	100	410	22	50	120	60.02	18	64	228 kg
	8.9"	5.2"	12.2"	9.8"	6.3"	14.4"	13.4"	18.5"	44.5"	4.9"	3.9"	16.1"	0.9"	2.0"	4.7"	2.4"	0.7"	2.5"	503 lb
14.06 - 21.41:1	250	150	370	290	185	440	400	507	1092	145	110	462	26	55	140	70.02	20	74.5	358 kg
	9.8"	5.9"	14.6"	11.4"	7.3"	17.3"	15.7"	20.0"	43.0"	5.7"	4.3"	18.2"	1.02"	2.2"	5.5"	2.8"	0.8"	2.9"	789 lb
23.04 - 35.09:1	315	220	410	340	260	490	450	578	1199	216	180	510	33	60	210	100.03	28	106	438 kg
	12.4"	8.7"	16.1"	13.4"	10.2"	19.3"	17.7"	22.8"	47.2"	8.5"	7.1"	20.1"	1.3"	2.4"	8.3"	3.9"	1.1"	4.2"	988 lb
39.45 - 63.08:1	355	215	500	380	260	590	530	660	1305	216	180	580	39	65	210	100.03	28	106	608 kg
	14.0"	8.5"	19.7"	15.0"	10.2"	23.2"	20.9"	26.0"	51.4"	8.5"	7.1"	22.8"	1.5"	2.6"	8.3"	3.9"	1.1"	4.2"	1362 lb
69.41 - 92.06:1	425	225	580	500	270	670	630	758	1373	216	180	630	39	100	210	120.03	32	127	768 kg
	16.7"	8.9"	22.8"	19.7"	10.6"	26.4"	24.8"	29.8"	54.1"	8.5"	7.1"	24.8"	1.5"	3.9"	8.3"	4.7"	1.3"	5.0"	1715 lb

FLANGE MOUNTED GEAR BOX DIMENSIONS

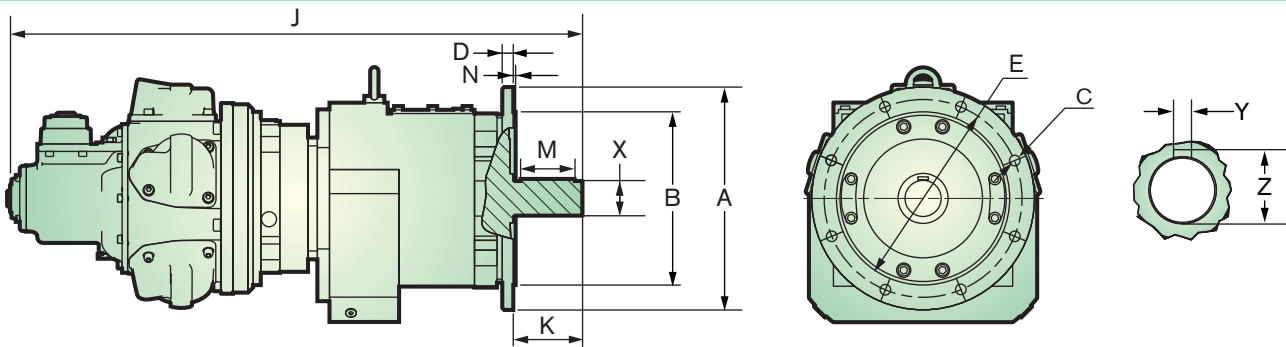

RANGE RATIO	A	B	C	D	E	J	K	M	N	X	Y	Y	MASS
3.42 - 12.68:1	450	350	17.5	20	400	1020	120	100	5	60.02	18	64	218 kg
	17.7"	13.8"	0.7"	0.8"	15.7"	40.2"	4.7"	3.9"	0.2"	2.4"	0.7"	2.5"	481 lb
14.06 - 21.41:1	450	350	17.5	22	400	1103	140	110	5	70.02	20	74.5	348 kg
	17.7"	13.8"	0.7"	0.9"	15.7"	43.4"	5.5"	4.3"	0.2"	2.8"	0.8"	2.9"	767 lb
23.04 - 35.09:1	450	350	17.5	22	400	1170	170	140	5	90.03	25	95	438 kg
	17.7"	13.8"	0.7"	0.9"	15.7"	46.1"	6.7"	5.5"	0.2"	3.5"	1.0"	3.7"	966 lb
39.45 - 63.08:1	550	450	17.5	31	500	1305	210	180	5	100.03	28	106	608 kg
	21.7"	17.7"	0.7"	1.2"	19.7"	51.4"	8.3"	7.1"	0.2"	3.9"	1.1"	4.2"	1340 lb
69.41 - 92.06:1	550	450	17.5	31	500	1392	210	180	5	120.03	32	127	768 kg
	21.7"	17.7"	0.7"	1.2"	19.7"	54.8"	8.3"	7.1"	0.2"	4.7"	1.3"	5.0"	1693 lb

Detailed drawings and CAD models available on request. Ratios above the basic range shown are available on request. Alternative gearbox types and arrangements i.e. right angle output, hollow shaft etc. also available.

Modified dimensions for shafts and flanges available on request.



RM610 VALVE OPTIONS

This range of bolt on valves offers very sensitive speed and directional control. One frictionless matched spool and sleeve assembly is offered with two alternative means of actuation.

CONFIGURATION

As standard these valves can be supplied with either EQUAL POWER or BIASED POWER spools, the latter is suitable for hoisting applications (normal power for lifting - reduced power for lowering).

The direction of reduced power must be stated when ordering CW or CCW, when viewed on the output shaft of the motor or geared motor.

1. Remotely Controlled (RCV) - This option is usually controlled from a remote position by one of the PC series or LC2 units. A variable air pilot signal is

applied to either end of the valve spool, depending on the required direction of motor rotation. The pilot pressure range is between 1.4 bar / 20 psi and 4.8 bar / 70 psi, increased pilot pressure give increased speed. The valve is spring centered to neutral.

2. Hand Controlled (HCV) - The control valve spool is operated directly by a lever mechanism. Speed increase is obtained as the lever is moved in either direction from the center (neutral) position.

Pressure Drop - Minimal pressure drop will be experienced through the valves, having the effect of maintaining the output torque while reducing the motor output speed by approximately 10-15% at 6 bar / 90 psi at maximum power. The starting torque remains unaffected.

REMOTE CONTROL VALVE - 1-1/2 BSP PORTS

Note: PM510 HCV and RCV can be used with this motor. Please contact SPX Hydraulic Technologies for performance details.

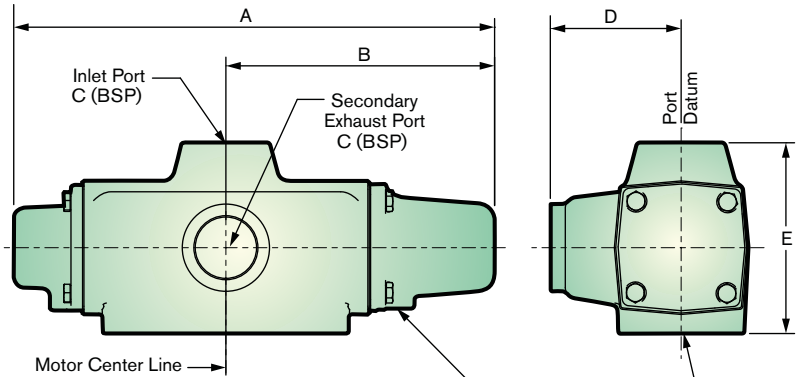
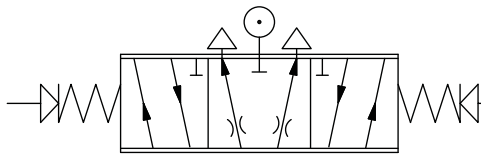

One Pilot Port each end 1/4" (BSP).
Cap may be positioned with port at top, bottom or either side.

A	B	C (BSP)	D	E	Approx. WT.
355.6	198.1	1-1/2	96.5	137.1	13.1 kg
14.0"	7.8"		3.8"	5.4"	30.11 lb

Modified threads and other valve options are available upon request. Please contact SPX Hydraulic Technologies.

HAND CONTROL VALVE - 1-1/2 BSP PORTS

Note: PM510 HCV and RCV can be used with this motor. Please contact SPX Hydraulic Technologies for performance details.

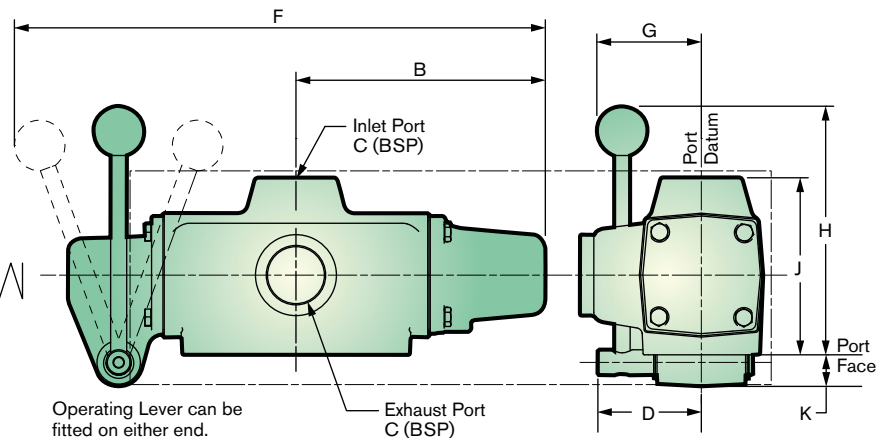
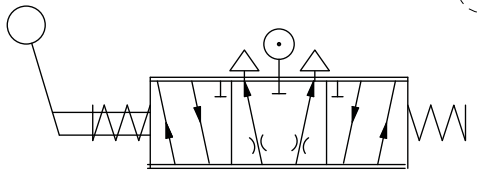

Operating Lever can be fitted on either end.

B	C (BSP)	D	F	G	H	J	K	Approx. WT.
198.1	1-1/2	96.5	414.0	86.3	190.5	137.1	27.9	13.1 kg
7.8"		3.8"	16.3"	3.4"	7.5"	5.4"	1.1"	30.11 lb

Modified threads and other valve options are available upon request. Please contact SPX Hydraulic Technologies.

RM610 VALVE OPTIONS SPARE PARTS LISTS

REMOTE CONTROL VALVE - 1-1/2 BSP PORTS

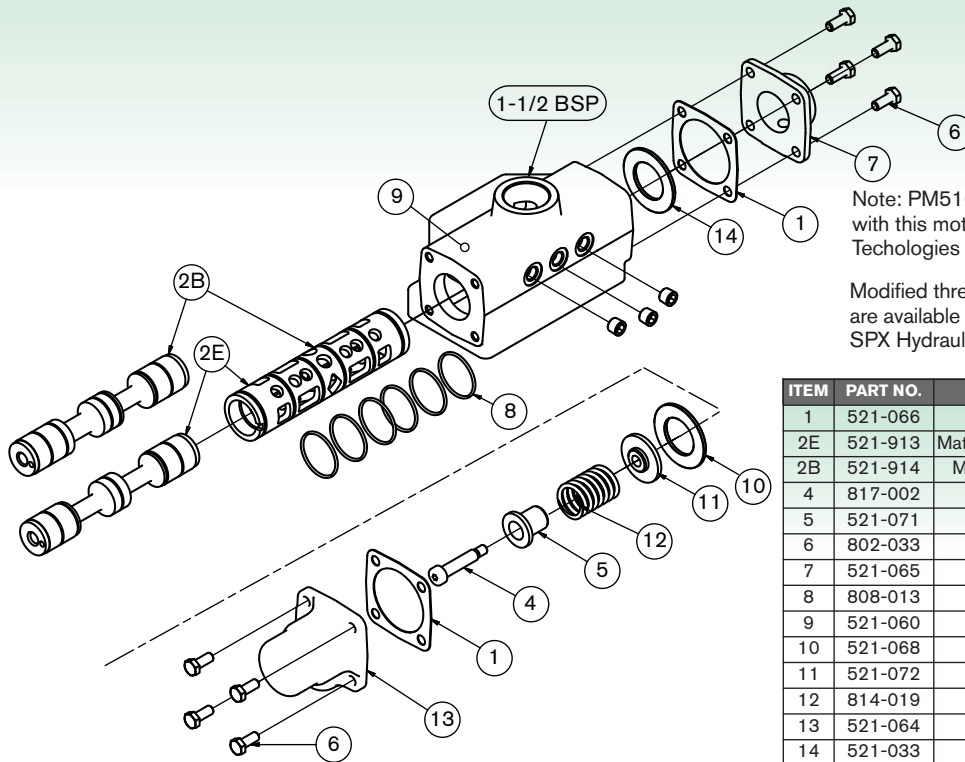

Note: PM510 HCV and RCV can be used with this motor. Please contact SPX Hydraulic Technologies for performance details.

Modified threads and other valve options are available upon request. Please contact SPX Hydraulic Technologies.

ITEM	PART NO.	DESCRIPTION	QTY.
1	521-066	End Cap Gasket	2
2E	521-913	Matched Spool and Sleeve (Equipower)	1
2B	521-914	Matched Spool and Sleeve (Biased)	1
4	817-002	Shoulder Screw 10mm	1
5	521-071	Centering Shaft Guide	1
6	802-033	Hex Head Screw M8 x 25	8
7	521-065	End Cap - Plain End	1
8	808-013	O-Ring 2" x 2-1/8"	6
9	521-060	Valve Body	1
10	521-068	Valve Sleeve Spacer	1
11	521-072	Washer, Spring Centering	1
12	814-019	Spring, Control Spool	1
13	521-064	End Cap - Spring End	1
14	521-033	End Cap Washer	1
15	816-074	Plug 1/4" BSPT	3

HAND CONTROL VALVE - 1-1/2 BSP PORTS

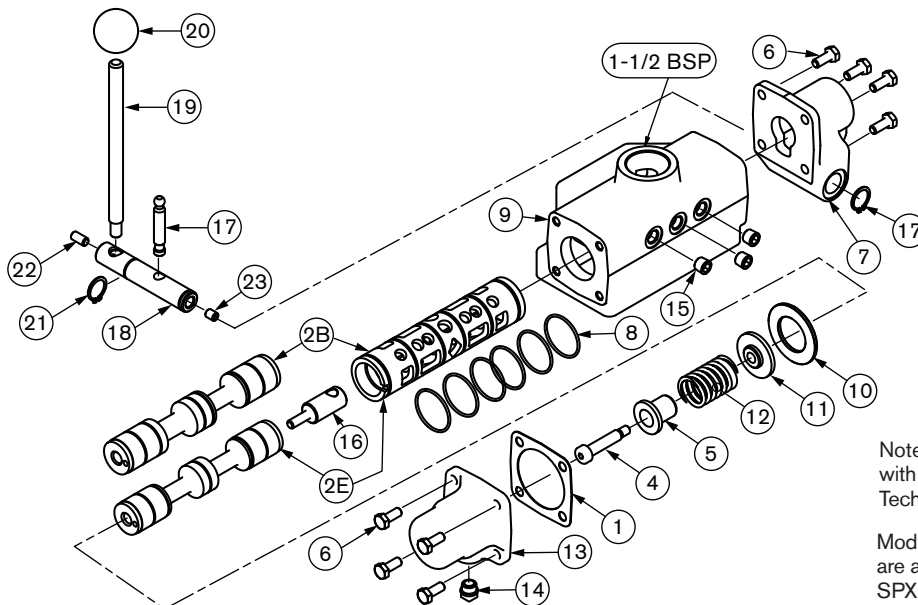

Note: PM510 HCV and RCV can be used with this motor. Please contact SPX Hydraulic Technologies for performance details.

Modified threads and other valve options are available upon request. Please contact SPX Hydraulic Technologies.

ITEM	PART NO.	DESCRIPTION	QTY.
1	521-066	End Cap Gasket	1
2E	521-913	Matched Spool and Sleeve (Equipower)	1
2B	521-914	Matched Spool and Sleeve (Biased)	1
4	817-002	Shoulder Screw 10mm	1
5	521-071	Centering Shaft Guide	1
6	802-033	Hex Head Screw M8 x 25	8
7	523-041	Lever Cap	1
8	808-013	O-Ring 2" x 2-1/8"	6
9	521-060	Valve Body	1
10	521-068	Valve Sleeve Spacer	1
11	521-072	Washer, Spring Centering	1
12	814-020	Spring Flexo 403824	1

ITEM	PART NO.	DESCRIPTION	QTY.
13	521-064	End Cap - Spring End	1
14	113-050	Vent Plug	1
15	816-074	Plug 1/4" BSPT	3
16	523-024	Toggle Shaft	1
17	523-026	Toggle Pin	1
18	523-008	Hand Lever Pivot	1
19	313-002	Hand Lever	1
20	818-002	Black Plastic Knob 1-1/2"	1
21	804-013	Circlip 20mm External	2
22	815-010	Grub Screw M8 x 10	1
23	815-002	Grub Screw M8 x 16	1



RM610 PARKING BRAKE INSTALLATION DETAILS

The brake module bolts directly onto the motor mounting face and has exactly the same interface as the motor. As shown on the drawing below, the brake consists of two spring applied shoes pressed against a central hub. These shoes are released by applying air pressure to the cylinder/piston assembly. The brake torque can be varied by means of two spring adjusters

but it is normally set so that a pilot pressure of 4.1 bar / 60 psi will fully release it. Pressures below this level will progressively reduce the braking torque available. The brakes are set at the plant but it may be necessary to make adjustments on site to suit the individual application.

BRAKE VIEW

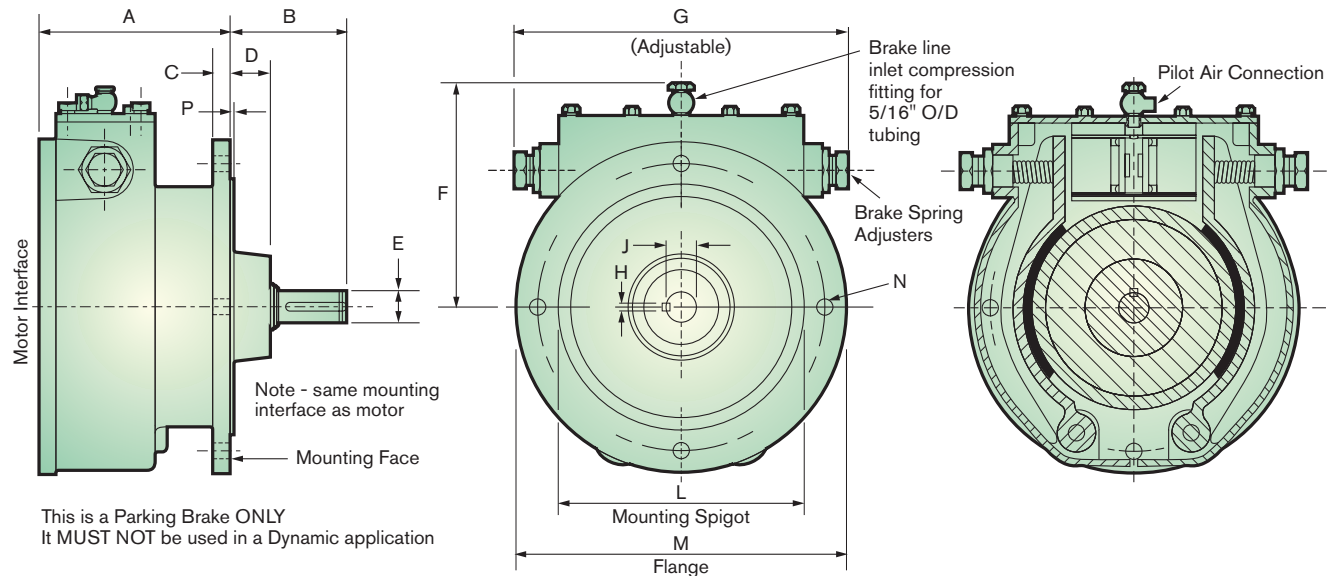

A	B	C	D	E	F	G	P	H	J	L	M	N-MOUNTING HOLES			
												NO.	Ø	P.C.D.	BOLT LENGTH (MAX)
172.7	96.5	16.0	16.0	35.0	269.2	449.5	5.0	9.9	37.8	309.9	386.0	127	18.0	350.5	38.1
6.8"	3.8"	0.63"	0.63"	1.3785"	10.6"	17.7"	0.2"	0.393"	1.4905"	12.2035"	15.2"	5"	0.71"	13.8"	1-1/2"

CIRCUITS

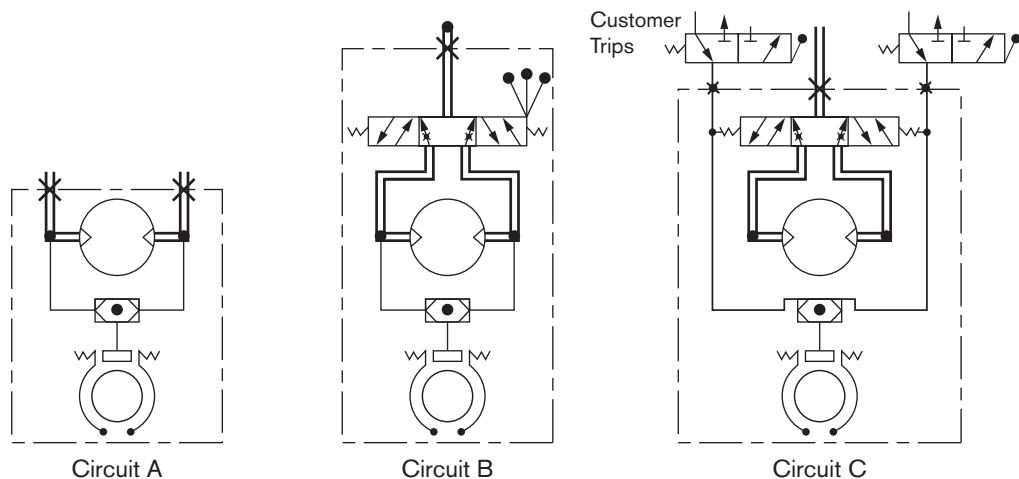

Circuit (A) - Applies to braked motors supplied without control valving. The unit will be fitted with a shuttle valve to allow brake operation for dual rotation.

Circuit (B) - Units supplied with hand (HCV) controlled reversible valves. If trips are required they must be of the mechanical style (customer's supply).

Circuit (C) - Units supplied with remotely controlled valves. When override trips are required, they must be superimposed in the signal line close to the motor unit and be of the 3 way style. (Signal lines cut and exhausted in the tripped position.)

RM610 PARKING BRAKE SPARE PARTS LIST & FOOT BRACKET

PARKING BRAKE SPARE PARTS LIST

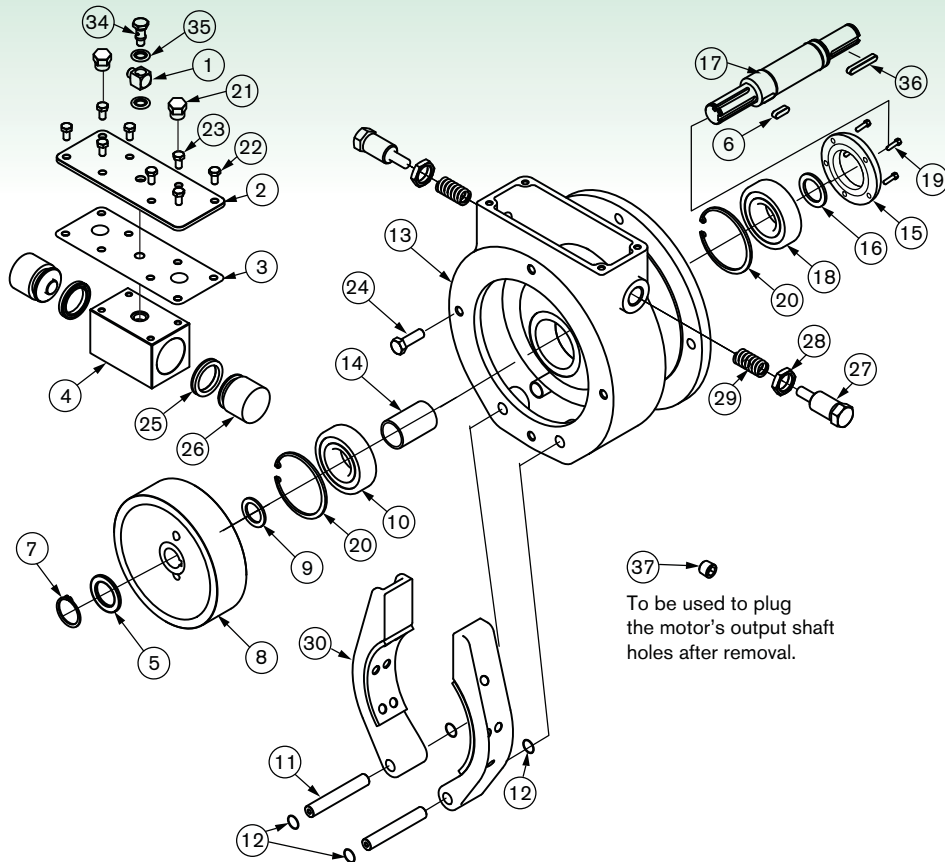

37
To be used to plug the motor's output shaft holes after removal.

ITEM	PART NO.	DESCRIPTION	QTY.
1	816-005	Banjo Body C/W Nut & Pin 5/16"	1
2	512-013	Plunger Plate	1
3	512-030	Gasket Plunger Block	1
4	512-021	Plunger Block	1
5	804-017	Circlip 40mm External	2
6	811-006	Key K130	1
7	808-002	O-Ring - 1/8" x 1-3/8"	1
8	512-001	Brake Wheel	1
9	512-036	Wheel Spacer	1
10	807-013	Bearing 6308 2RS	1
11	412-003	Pin	2
12	803-003	Washer M16	6
13	512-008	Brake Housing	1
14	518-001	Output Bearing Spacer	1
15	518-002	Output Bearing Housing Cap	1
16	808-042	Oilseal 48 x 62 x 8/R4	1
17	512-005	Brake Shaft	1

ITEM	PART NO.	DESCRIPTION	QTY.
18	807-063	Roller Bearing	1
19	802-016	Hex Head Screw M6 x 16	5
20	804-068	Circlip 90mm External	3
21	816-265	Screw Plugs (Bluemay)	2
22	802-053	Set Screw M10 x 25	4
23	802-052	Set Screw M10 x 20	4
24	802-094	Bolt M6 x 40 Hex Head	5
25	808-071	U Packing U132	2
26	512-011	Plunger	2
27	512-009	Adjuster Screw	2
28	512-024	Locknut	2
29	814-011	Spring MSD15	2
30	512-901	Brake Shoe Assembly	2
34	816-006	Banjo Bolt 1/4" BSP	1
35	808-090	Bonded Seal 1/4" BSP Dowty	2
36	811-030	Key 10 x 8 x 63	1



FOOT BRACKET

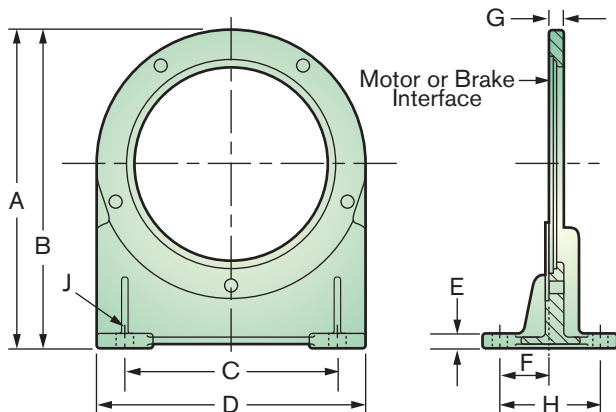

A	B	C	D	E	F	G	H	J
457.2	264.0	304.8	386.0	22.86	70.1	22.8	146.0	4 x Ø 18.0
18.0"	10.394"	12.00"	15.2"	0.9"	2.76"	0.9"	5.75"	4 x Ø 0.71"

REMOTE CONTROLLERS

PENDANT CONTROLS (PC2, 4 OR 6)

The PC2, 4 and 6 remote controllers are designed specifically for use with the RCV modules. They provide the correct range of pilot pressure required to operate the RCV units, and give excellent control of motor speed. The PC2 is used to control one (hoist) motor; the PC4 can control two motors independently (say hoist and long travel); the PC6 can control three motors independently (hoist, long travel, traverse). Motors of different sizes can be controlled from the same unit.

Control line lengths of 36 m / 120 ft. give excellent response. For distance in excess of this contact factory. The control lines are small bore eliminating the need for large capacity air supply lines between motor and controller. If required, supply pressure can be taken from the tapping on the RCV. MARINE VERSION AVAILABLE. PC2M, PC4M OR PC6M.

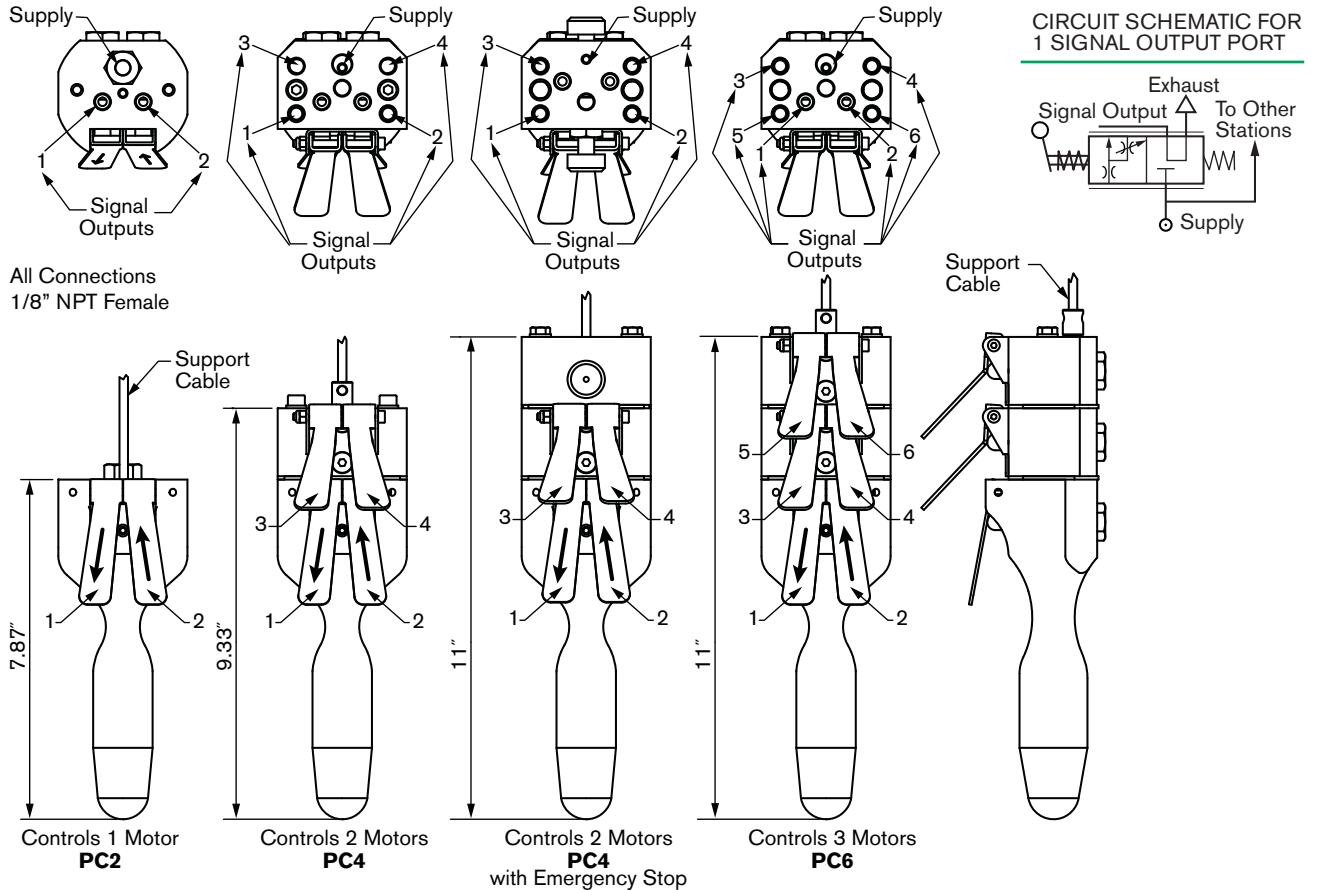

LEVER CONTROL (LC2) MARINE STYLE (LC2M)

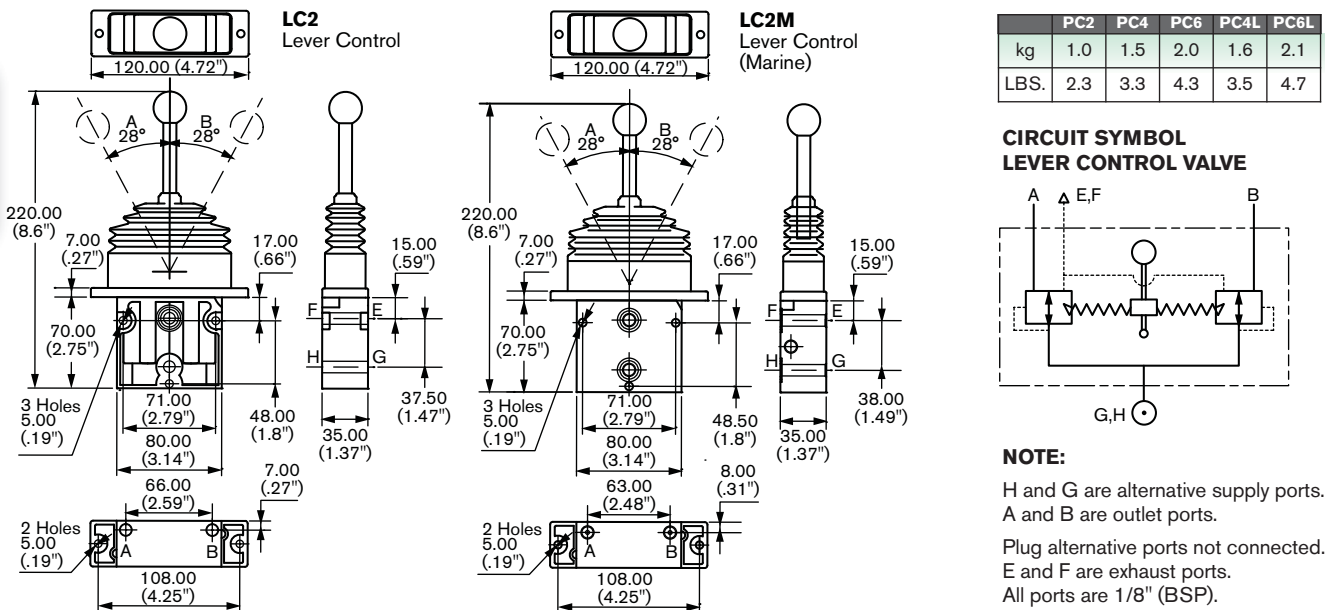

ACCESSORIES MUFFLERS

MUFFLERS

Mufflers screw directly into the primary and secondary exhaust ports. **Note** - control valves also have secondary exhaust ports.

These mufflers are designed for intermittent use. For continuous operation contact factory.

If it is necessary to pipe the exhaust away from the motor, care must be taken to adequately size the pipework to avoid build up of back pressure in the system. If in doubt consult our Applications Department.

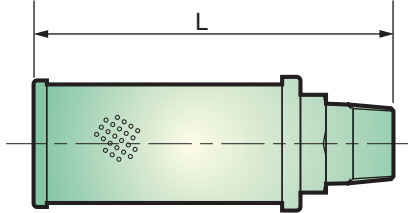

	110 PRIMARY	110 SECONDARY	210 PRIMARY	210 SECONDARY	310	410	510	610
SIZE	19.05	12.70	25.40	19.05	31.75	31.75	38.10	50.80
	3/4"	1/2"	1"	3/4"	1-1/4"	1-1/4"	1-1/2"	2"
L	171.45	139.7	203.2	171.45	209.55	209.55	336.55	463.55
	6.75	5.5	8.0	6.75	8.25	8.25	13.25	18.25

Normally supplied in kit form complete with fittings.



4-7

**World Headquarters
The Americas
Customer Service Center**

5885 11th Street
Rockford, Illinois 61109
Tel: 815-874-5556

Customer Service/
Order Entry
Tel: 800.541.1418
Fax: 800.288.7031

**European
Customer Service Center**

Albert Thijsstraat 12
6471 WX Eygelshoven
The Netherlands
Tel: 31 (45) 5678877
Fax: 31 (45) 5678878
infoeurope@powerteam.com

**Asia Pacific
Customer Service Center**

7 Gul Circle
Singapore 629563
Singapore
Tel: (65) 6265 3343
Fax: (65) 6265 6646
infoasia@powerteam.com

**China
Customer Service Center**

No. 1568 Hua Shan Road
Treasury Building
1102, 11th Floor
Shanghai 200052, P.R. China
Tel: 86 (21) 2208.5888
Fax: 86 (21) 2208.5682
infochina@powerteam.com

8-14



15-21



Technical Services
Tel: 800.477.8326
Fax: 800.765.8326
info@powerteam.com

22-28



29-35



36-42



43-49



50



51

**GLOBEAIRMOTORS.COM****Distributed by:**